



eMotiv Range

LED Electric Fire Range
with Thermostatic Remote Control



Instructions for Servicing

For use in

Great Britain & Republic of Ireland
Éire
République Française
Deutschland
Nederland
Italia

Norge
España
Ελλάδα
Latvijas Republika
Groussherzogtum Lëtzebuerg
República Portuguesa

eMOTIV 64	eMOTIV 74	eMOTIV 84
210-364	210-390	210-414

GB

Contents

Pairing The Remote Control..... 4
 Maintenance..... 10
 Log Layout.....11
 Wiring Diagram..... 29
 Spare Parts List..... 32
 Information Requirement - Electric Heaters 34

FR

Contenu

Appairer La Télécommande 4
 Maintenance..... 10
 Agencement Des Bûches11
 Pschéma De Câblage..... 29
 Liste Des Principales Pièces De Rechange..... 32
 Informations à fournir pour un appareil de chauffage
 électrique localisé 34

DE

Inhalt

Koppeln der Fernbedienung 5
 Instandhaltung..... 10
 Nordnung Der Holzscheite11
 Schaltplan 29
 Ersatzteilliste 32
 Technische Informationen - Elektrische Heizgeräte 34

NL

Inhoud

De Afstandsbediening Koppelen 5
 Onderhoud 10
 Blokken-Layout.....11
 Bedradingschema 29
 Lijst Standaard Reserve Onderdelen 32
 Informatie-eisen voor elektrische toestellen voor
 lokale ruimteverwarming 34

IT

Contenuto

Coppiamento Telecomando..... 6
 Manutenzione..... 10
 Schema Dei Ceppi11
 Schema Di Cablaggio..... 29
 Listino Prezzi Dei Ricambi 32

NO

Innhold

Sammenkoble Fjernkontrollen..... 6
 Vedlikehold..... 10
 Kubbeoppsett11
 Koblingsdiagram 29
 Reservdeliste 32



CONSUMER SUPPORT VIDEO:
www.gazco.tv/support/eMotiv



ES

Contenido

Sincronización Del Mando A Distancia	7
Mantenimiento	10
Distribución De Los Leños.....	11
Esquema De Cableado.....	29
Relación De Repuestos	32

GR

Περιεχόμενα

Σύνδεση του τηλεχειριστηρίου	7
Συντήρηση	10
Διαταξη Ξυλων.....	11
Ηλεκτρικο Διαγραμμα.....	29
Καταλογος Ανταλλακτικων	32

LV

Saturs

Tālvadības pults un ierīces savienošana pārī	8
Apkope	10
Pagaļu Izvietojums	11
Elektroinstal Cijas Diagramma.....	29
Vrezerves Daļu Saraksts.....	32

LU

Inhalt

Koppele vun der Fernsteuerung	8
Ënnerhalt.....	10
Holzstéckerlayout.....	11
Verkabelungsdiagramm.....	29
Ersatzdeelerlëscht.....	32

PT

Conteúdos

Emparelhar o controlo remoto	9
Manutenção.....	10
Esquema De Troncos.....	11
Diagrama De Cablagem	29
Lista De Peças Sobresselentes	32

GB: PAIRING THE REMOTE CONTROL TO THE APPLIANCE

Signal Code

The below operations should be carried out before coding when changing to a new remote or the unit cannot be controlled by the remote:

Press the power button until 2 short beeps sound from the unit, release the button.

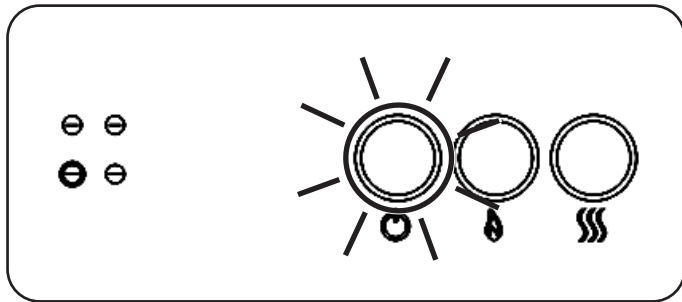

3 seconds



2 Beeps

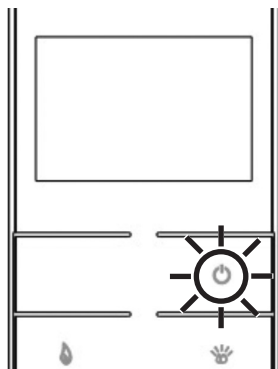

1 Beep

Within 10 seconds, press the  button on remote. The coding is finished when 1 long beep sounds from the unit.

Resetting of the remote control is necessary if the appliance operates wrongly due to external interference signal and the remote control is not in use.

Open the back cover of the Remote.

Press the Reset button for 3 seconds and reset the coding.



FR: APPAIRER LA TÉLÉCOMMANDE AVEC L'APPAREIL

Code de signal

Les opérations ci-dessous doivent être menées avant le codage lors du remplacement d'une télécommande ou lorsque l'unité ne peut pas être contrôlée par la télécommande :

Appuyez sur le bouton d'alimentation jusqu'à ce que 2 bips courts retentissent de l'unité, relâchez le bouton.

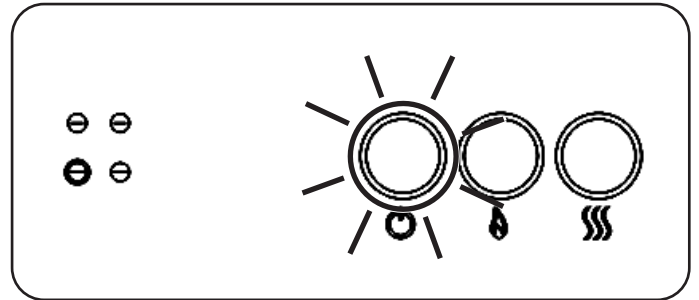

3 seconds



2 Beeps

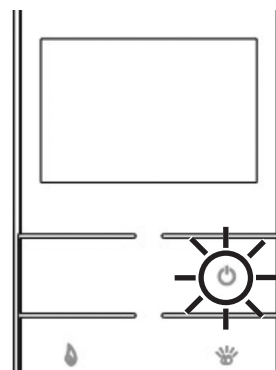

1 Beep

Au bout de 10 secondes, appuyez sur le bouton  de la télécommande. Le codage est terminé lorsque 1 long bip est émis par l'unité.

Une réinitialisation de la télécommande est nécessaire si l'appareil fonctionne de manière anormale en raison d'interférences causées par un signal externe et si la télécommande n'est pas utilisée.

Ouvrez le couvercle arrière de la télécommande.

Appuyez sur le bouton de réinitialisation pendant 3 secondes et réinitialisez le codage.





DE: KOPPELN DER FERNBEDIENUNG MIT DEM GERÄT

Signalcode

Die folgenden Schritte sollten vor der Koppelung durchgeführt werden, wenn Sie zu einer neuen Fernbedienung wechseln oder das Gerät nicht über die Fernbedienung gesteuert werden kann:

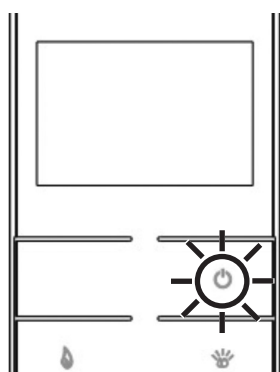
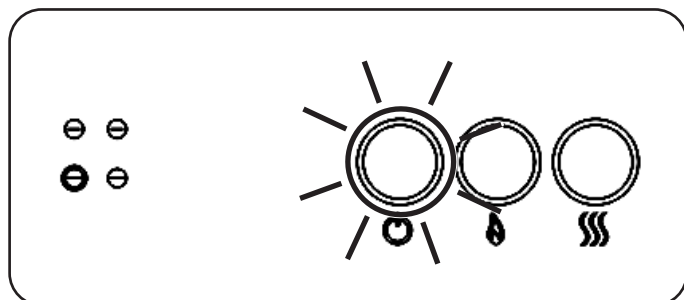
Drücken Sie den Ein/Aus-Taste, bis 2 kurze Signaltöne vom Gerät ausgehen, und lassen Sie die Taste los.



Drücken Sie  innerhalb von 10 Sekunden die Taste auf der Fernbedienung. Die Kopplung ist beendet, wenn 1 langer Signalton vom Gerät ertönt.

Ein Rücksetzen der Fernbedienung ist erforderlich, wenn das Gerät aufgrund eines externen Störsignals fehlerhaft arbeitet und die Fernbedienung nicht verwendet werden kann..

Öffnen Sie die hintere Abdeckung der Fernbedienung Drücken Sie die Reset-Taste 3 Sekunden lang, um die Kopplung zurückzusetzen.



NL: DE AFSTANDSBEDIENING KOPPELEN AAN HET TOESTEL

Signaalcode

De handelingen hieronder moeten worden uitgevoerd vóór codering wanneer wordt overgegaan op een nieuwe afstandsbediening; anders zal de eenheid niet kunnen worden bestuurd door de afstandsbediening:

Houd de aan / uit-knop ingedrukt totdat er 2 korte pieptonen klinken uit het apparaat, laat de knop los.

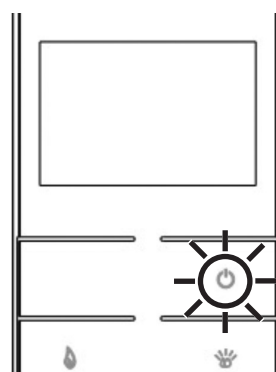
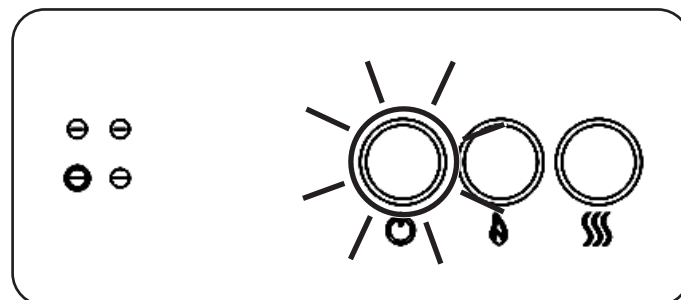

Druk binnen 10 seconden op de -knop op de afstandsbediening. De codering is voltooid wanneer 1 lange piep vanuit de eenheid klinkt.

Het nodig is om de afstandsbediening te resetten als het toestel op onjuiste wijze werkt ten gevolge van een extern interferentiesignaal wanneer de afstandsbediening niet gebruikt wordt.

Open de achterkant van de afstandsbediening. Houd de resetknop voor 3 seconden ingedrukt en reset decodering,



IT: COPPIAMENTO TELECOMANDO APPARECCHIO

Codice di segnale

Le seguenti operazioni devono essere eseguite prima della codifica quando si passa a un nuovo telecomando o l'unità non può essere controllata dal telecomando:

Premere il pulsante di accensione per finché non vengono emessi 2 brevi segnali acustici dall'unità, rilasciare il pulsante.

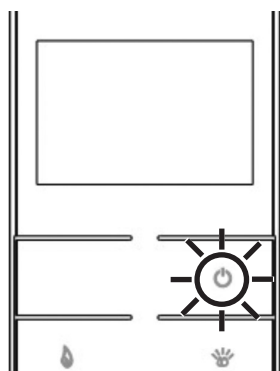
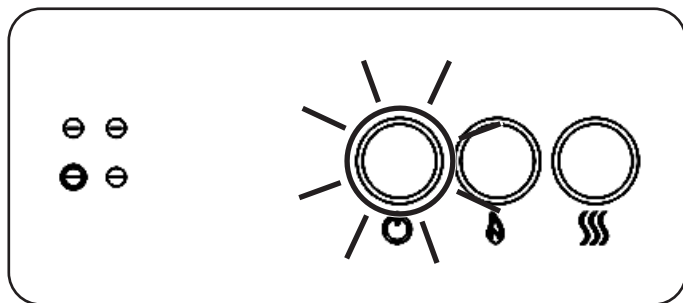

Nel giro di 10 secondi, premere il pulsante sul telecomando. La codifica termina quando viene emesso 1 lungo bip dall'unità.

Il ripristino del telecomando è necessario se l'apparecchio funziona in modo errato a causa di un segnale di interferenza esterno e il telecomando non è in uso.

Aprire il coperchio posteriore del telecomando.
Premere il pulsante di ripristino per 3 secondi e ripristinare la codifica.



NO: SAMMENKOBLE FJERNKONTROLLEN

Signalkode

Den nedenstående operasjonen skal utføres før koding når du skifter til en ny fjernkontroll eller dersom enheten ikke kan styres av fjernkontrollen:

Trykk på av / på-knappen til det høres 2 korte pip fra enheten, slipp knappen.

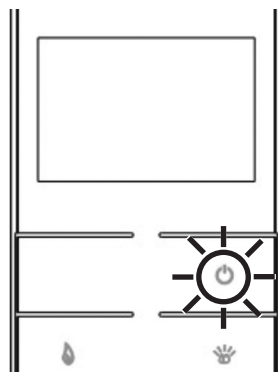
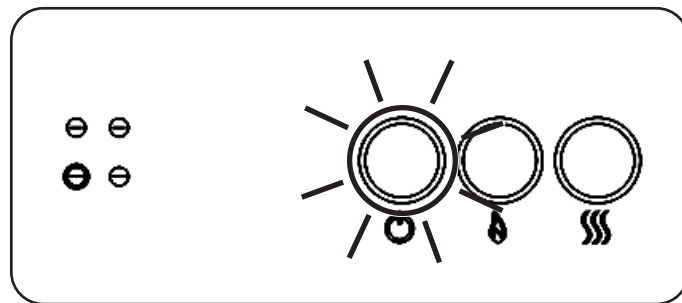

Innen 10 sekunder, trykk på knappen på fjernkontrollen. Kodingen er fullført når 1 lang pipelyd kan høres fra enheten.

Å tilbake stille fjernkontrollen kan være nødvendig dersom apparatet fungerer feilaktig på grunn av eksterne interferens-signaler og fjernkontrollen ikke er i bruk.

Åpne det bakre dekselet på fjernkontrollen.

Trykk på tilbakestillings-knappen i 3 sekunder og tilbakestill kodingen.





ES: SINCRONIZACIÓN DEL MANDO A DISTANCIA AL APARATO

Código de aviso

Las siguientes operaciones deben llevarse a cabo antes de codificar el nuevo mando a distancia, o la no se podrá controlar con el mando:

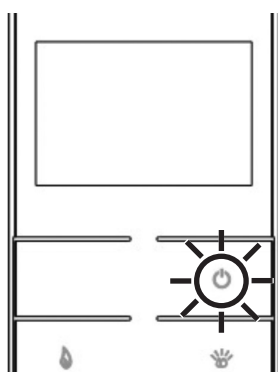
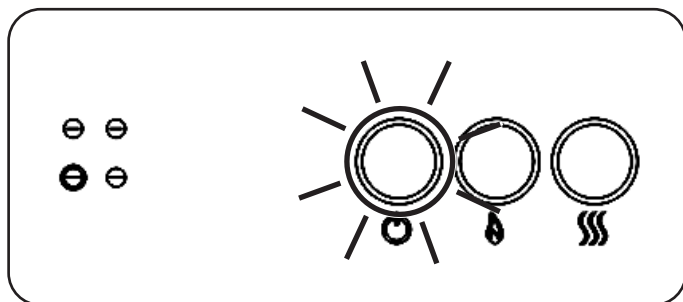
Presione el botón de encendido hasta que suenen 2 pitidos cortos en la unidad, suelte el botón.



En 10 segundos, presione el botón  en el mando a distancia. La codificación termina cuando suena un largo pitido.

El reinicio del mando es necesario si el aparato funciona incorrectamente debido a una señal de interferencia externa y el mando a distancia no está en uso.

Abra la cubierta posterior del mando.

Pulse el botón de reinicio durante 3 segundos y reinicia la codificación.





GR: ΣΥΝΔΕΣΗ ΤΟΥ ΤΗΛΕΧΕΙΡΙΣΤΗΡΙΟΥ ΜΕ ΤΗ ΣΥΣΚΕΥΗ

Κωδικός σήματος

Οι παρακάτω ενέργειες πρέπει να εκτελούνται πριν από την κωδικοποίηση όταν το τηλεχειριστήριο αντικαθίσταται από νέο ή δεν μπορεί να ελέγξει τη μονάδα:

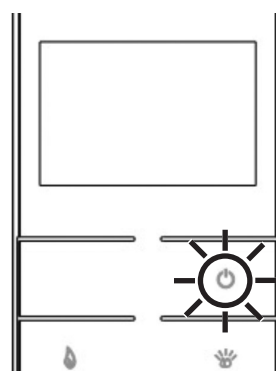
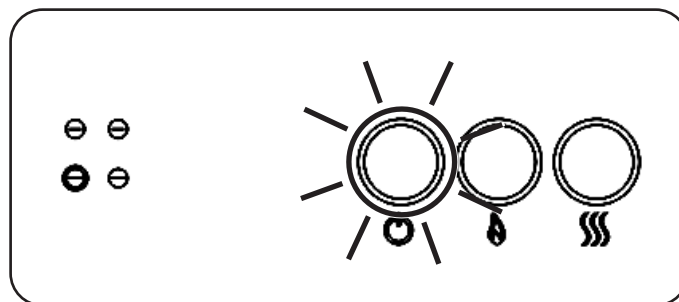
Πιέστε το κουμπί Reset για 2 δευτερόλεπτα και επαναφέρετε την κωδικοποίηση.



Μέσα σε 10 δευτερόλεπτα, πιέστε το  κουμπί στο τηλεχειριστήριο. Η κωδικοποίηση ολοκληρώνεται όταν ακουστεί από τη μονάδα ένα παρατεταμένο «μπιπ».

Η επαναφορά του τηλεχειριστηρίου είναι απαραίτητη αν η συσκευή λειτουργεί εσφαλμένα λόγω επέμβασης από εξωτερικό σήμα και δεν χρησιμοποιείται το τηλεχειριστήριο.

Ανοίξτε το πίσω κάλυμμα του τηλεχειριστηρίου.

Πιέστε το κουμπί Reset για 3 δευτερόλεπτα και επαναφέρετε την κωδικοποίηση.





LV: TĀLVADĪBAS PULTS UN IERĪCES SAVIENOŠANA PĀRĪ

Signāla kods

Tālāk norādītās darbības jāveic pirms kodēšanas, kad tiek nomainīta tālvadības pults vai ierīci nevar pārvaldīt ar tālvadību:

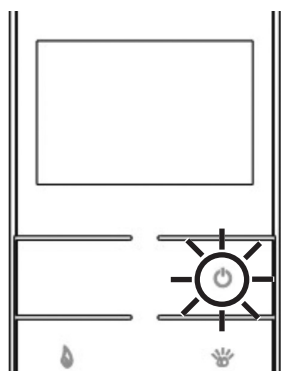
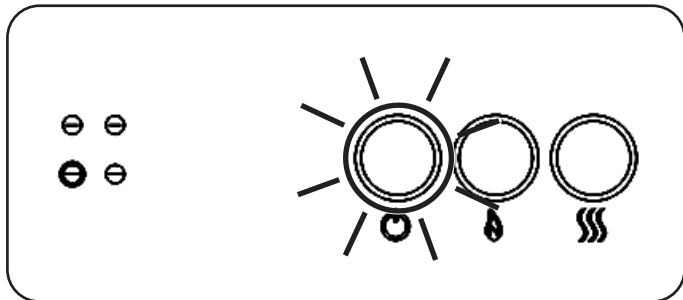
Spiediet atiestatīšanas pogu 3 sekundes līdz no ierīces atskan 2 īsi skaņas signāli.



10 sekunžu laikā piespiediet pogu  uz tālvadības pults. Kodēšana ir pabeigta, kad nav ierīču atskan 1 garš skaņas signāls.

Tālvadības pulti var būt nepieciešams atiestatīt, ja ierīce darbojas nepareizi ārējā signāla dēļ, kas rada traucējumus, un tālvadības pults netiek lietota.

Atveriet tālvadības pults aizmugurējo paneli.

Spiediet atiestatīšanas pogu 3 sekundes un atiestatiet kodējumu.



LU: KOPPELE VUN DER FERNSTEUERUNG MAM APPARAT

Signalcode

Dēi follgend Schrētt sollte virun der Codéierung ausgefiert ginn, wann Dir op eng nei Fernsteuerung wiesselt oder den Apparat net iwwer d'Fernsteuerung gesteiert ka ginn:

Dréckt den Heizungschalter bis 2 kuerz Piptéin vum Apparat ausgi ginn a loosst de Knäppche lass.

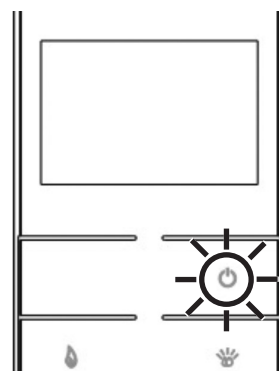
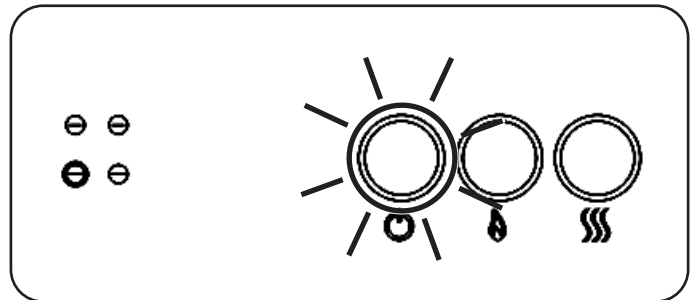

Dréckt bannent 10 Sekonnen

de Knäppchen  op der Fernsteuerung.

D'Codéierung ass offgeschloss, wann 1 laange Piptoun vum Apparat ertéint.

D'Zerécksetze vun der Fernsteuerung ass erfuerderlech, wann den Apparat opgrond vun engem externe Stéiersignal falsch funktionéiert an d'Fernsteuerung net verwent gëtt.

Maacht déi hënnescht Ofdeckung vun der Fernsteuerung op.

Dréckt de Resetknäppchen 3 Sekonne laang a setzt d'Codéierung zeréck.



PT: EMPARELHAR O CONTROLO REMOTO COM O APARELHO

Código de Sinal

As operações abaixo devem ser realizadas antes da codificação ao mudar para um novo controlo remoto ou quando a unidade não puder ser controlada pelo controlo remoto:

Pressione o botão de energia até ouvir 2 bipes curtos da unidade e solte o botão.

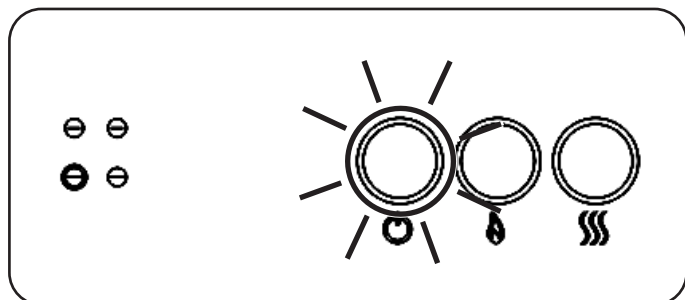

3 seconds



2 Beeps

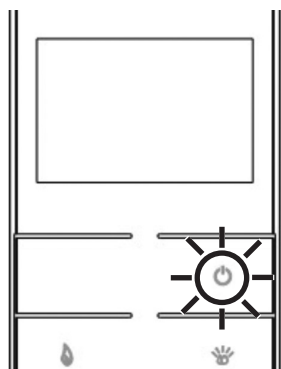

1 Beep

Em 10 segundos, pressione o  botão no controlo remoto. A codificação estará concluída quando ouvir um bip longo da unidade.

É necessário reiniciar o controlo remoto se o aparelho funcionar incorretamente devido a um sinal de interferência externa e o controlo remoto não estiver a ser usado.

Abra a tampa traseira do controlo remoto. Pressione o botão Reset durante 3 segundos e reinicie a codificação.



GB: ACCESSING THE FUEL BED

FR: ACCÈS AU LIT DE COMBUSTIBLE

DE: OPTIONALE LED-STIMMUNGSBELEUCHTUNG

NL: TOEGANG TOT HET BRANDSTOFBED

IT: ACCESSO AL CROGIOLO DI COMBUSTIONE

NO: TILGANG TIL BRENNKAMMERET

ES: ACCESO AL LECHO DE COMBUSTIBLE

GR: ΠΡΟΣΒΑΣΗ ΣΤΗΝ ΚΛΙΝΗ ΚΑΥΣΙΜΟΥ

LV: PIEKĻUVE DEGOŠAJAM SLĀNIM

LU: ZOUGANG ZUM BRENNSTOFFBETT

PT: ACESSO AO LEITO DE COMBUSTÍVEL

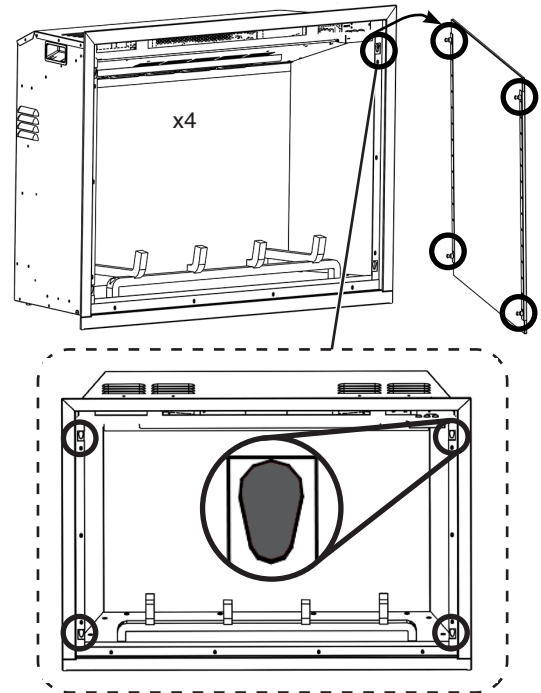
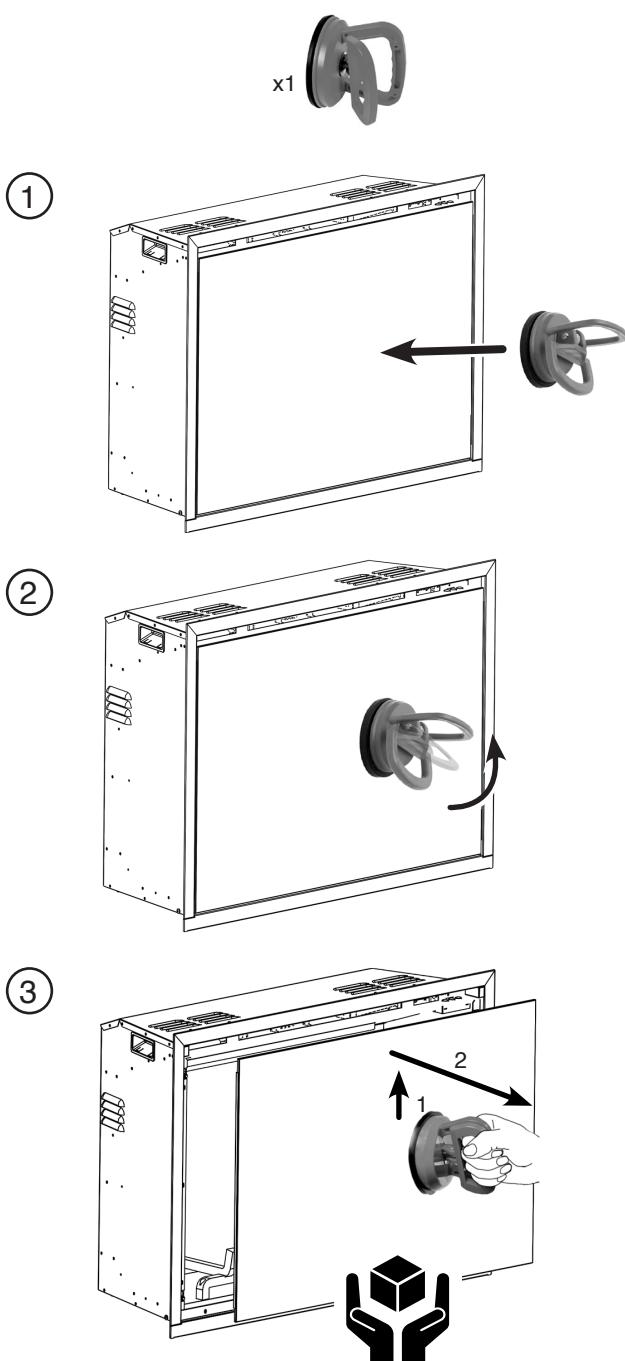

GB: LOG SET - LOG LAYOUT

FR: JEU DE BÛCHES - AGENCEMENT DES BÛCHES

DE: HOLZSCHEIT-SET - ANORDNUNG DER
HOLZSCHEITE

NL: BLOKKEN GEPLAATST - BLOKKEN-LAYOUT

IT: SET DI CEPPI - SCHEMA DEI CEPPI

NO: KUBBESETT - KUBBEOPPSETT

ES: CONJUNTO DE LEÑOS - DISTRIBUCIÓN DE LOS
LEÑOS

GR: ΠΟΙΚΙΛΙΑ ΞΥΛΩΝ - ΔΙΑΤΑΞΗ ΞΥΛΩΝ

LV: PAGAĻU KOMPLEKTS - PAGAĻU IZVIETOJUMS

LU: HOLZSTÉCKERSAZ - HOLZSTÉCKERLAYOUT

PT: CONJUNTO DE TRONCOS - ESQUEMA DE
TRONCOS

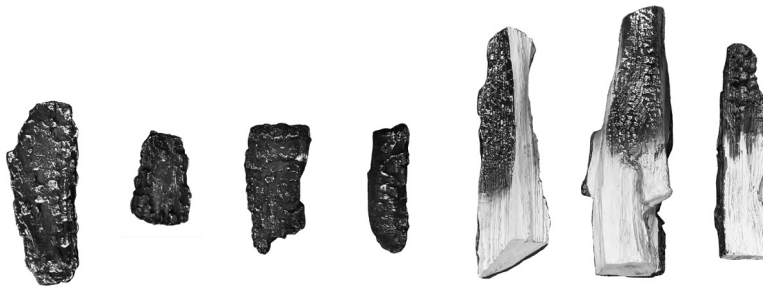

	A	B	C	D	E	F	G
eMOTIV 64	4	3	2	0	1	1	3
eMOTIV 74	5	7	3	4	1	1	3
eMOTIV 84	7	8	3	3	2	2	1

(H)



GB: Glass Embers
FR: Braises De Verre
DE: Glasglut
NL: Glazen Sintels
IT: Ciochi In Vetro
NO: Glassglør
ES: Brasas De Vidrio
GR: Διακοσμητικά
Καρβουνα
LV: Stikla Ogles
LU: Glasglous
PT: Brasas Em Vidro

(I)



GB: Amber Crystals
FR: Cristaux Ambrés
DE: Ingwerfarbene
Kristalle
NL: Roodachtige kristallen
IT: Cristalli zenzero
NO: Oransje krystaller
ES: Cristales anaranjados
GR: Χαλκοκόκκινοι
κρύσταλλοι
LV: Oranži kristāli
LU: Geltoni kristalai
PT: Cristais laranjas

eMOTIV 64

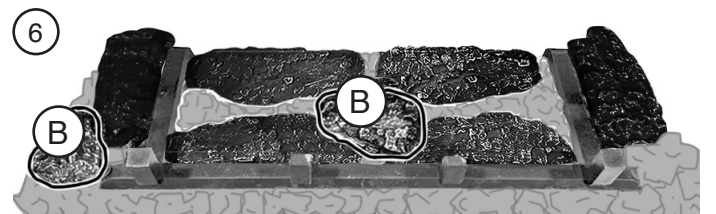
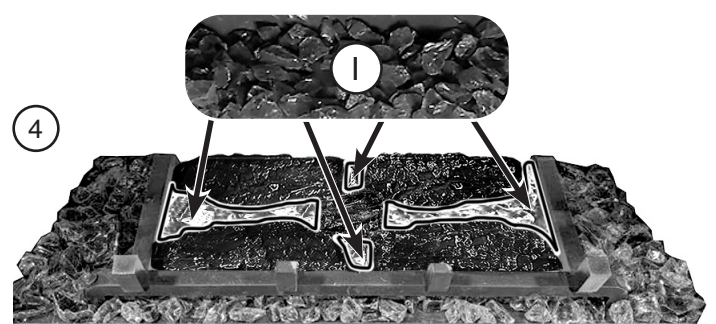
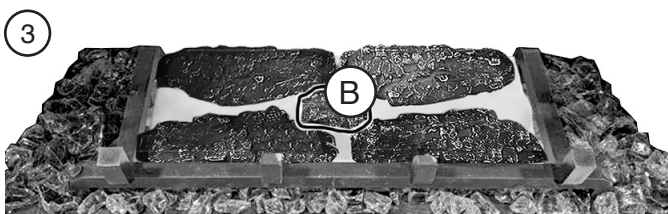
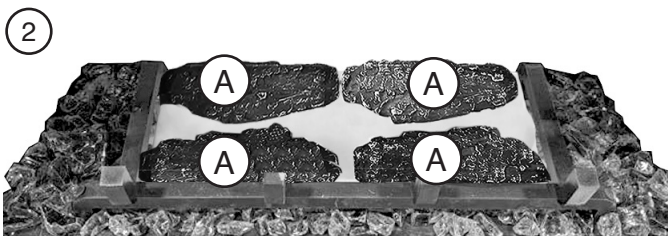
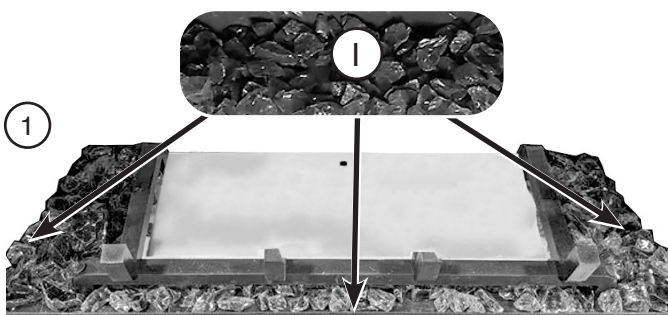

7

- GB:** Place Glass Embers (H) evenly with white sides facing up.
FR: Disposez les Braises De Verre (H) uniformément, les faces blanches vers le haut.
DE: Glasglut (H) gleichmäßig mit der weißen Seite nach oben platzieren.
NL: Plaats Glazen Sintels (H) gelijkmatig met witte kanten naar boven gericht.
IT: Disporre le Ciochi In Vetro (H) in modo uniforme con i lati bianchi rivolti verso l'alto.
NO: Plasser Glassglør (H) jevnt med de hvite sidene vendt opp.
ES: Distribuya uniformemente las Brasas De Vidrio (H) con las caras blancas mirando hacia arriba.
GR: Τοποθετήστε τα Διακοσμητικά Καρβουνα (H) ομοιόμορφα με τη λευκή πλευρά προς τα πάνω.
LV: Stikla Ogles (H) vienmērīgi novietojiet ar balto pusi uz augšu.
LU: Glasglous (H) tolygiai paskleiskite baltajā pusē j viršū.
PT: Coloque as Brasas Em Vidro (H) de forma uniforme com os lados brancos virados para cima.

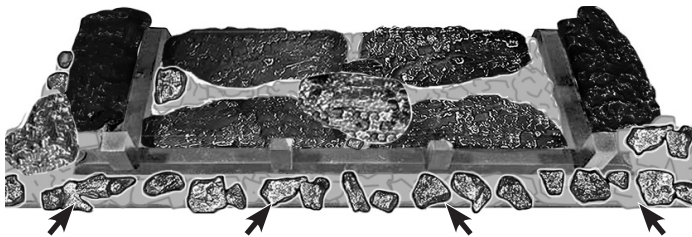

8

- GB:** Apply adhesive tape to logs at white dot positions
FR: Appliquez du ruban adhésif sur les bûches à l'emplacement des points blancs.
DE: Bringen Sie Klebeband an den weißen Punkten auf den Holzscheiten an.
NL: Breng klevende tape aan op de witte stippen op de houtblokken.
IT: Applicare il nastro adesivo ai ceppi in corrispondenza dei punti bianchi.
NO: Bruk teip på vedkubber i posisjoner med hvite prikker.
ES: Aplique cinta adhesiva a los troncos en las posiciones de los puntos blancos.
GR: Εφαρμόστε κολλητική ταινία στα κούτσουρα εκεί που είναι οι λευκές βούλες.
LV: Uzliņmējiet līmteni uz pagalmē balto punktu vietās.
LU: Ant rāstų baltų taškų vietose užklijuokite lipniąją juostą.
PT: Aplique fita adesiva nos troncos, nos locais com pontos brancos.

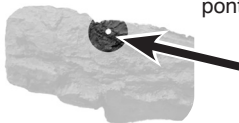

9

- GB:** Adhesive Tape
FR: Ruban adhésif
DE: Klebeband
NL: Klevend tape
IT: Nastro adesivo
NO: Teip
ES: Cinta adhesiva
GR: Κολλητική ταινία
LV: Līmtenle
LU: Lipnioji juosta
PT: Fita adesiva



10

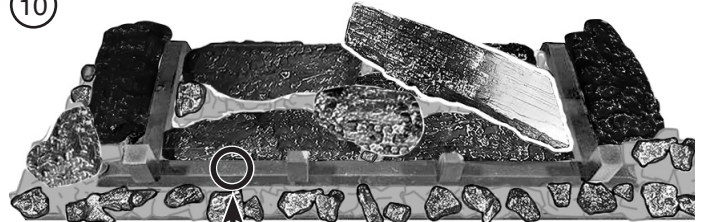

- GB:** Adhesive Tape x1
FR: Ruban adhésif x1
DE: Klebeband x1
NL: Klevend tape x1
IT: Nastro adesivo x1
NO: Teip x1
ES: Cinta adhesiva x1
GR: Κολλητική ταινία x1
LV: Līmtenle x1
LU: Lipnioji juosta x1
PT: Fita adesiva x1

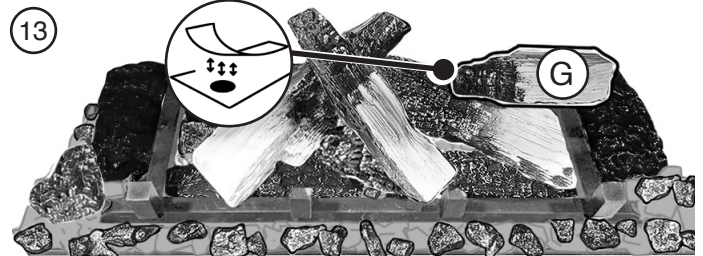
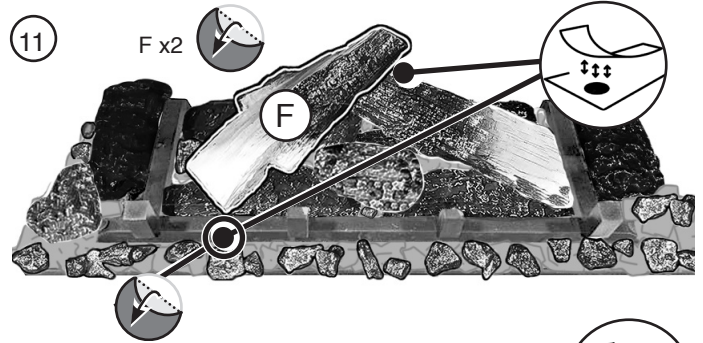

eMOTIV 74

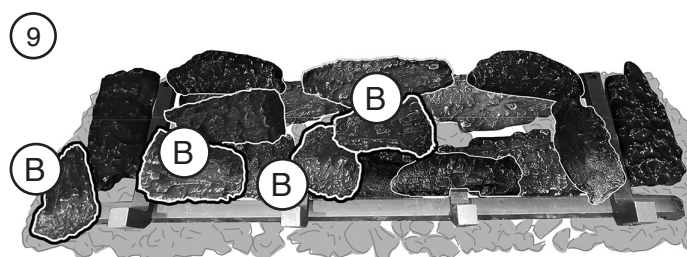
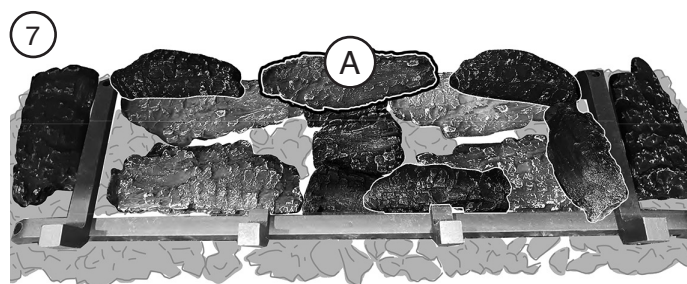
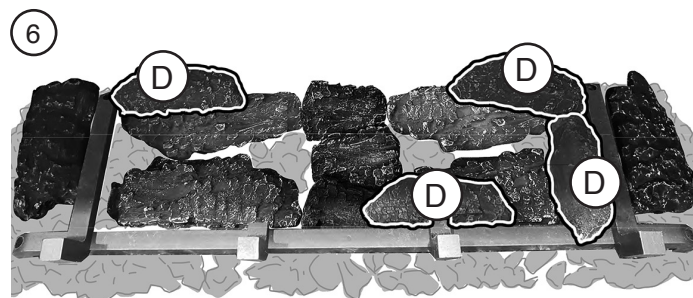
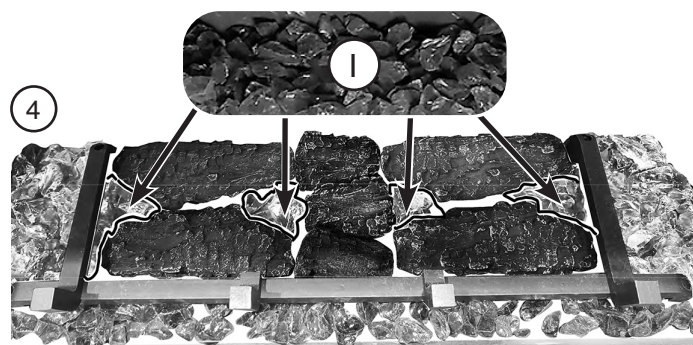
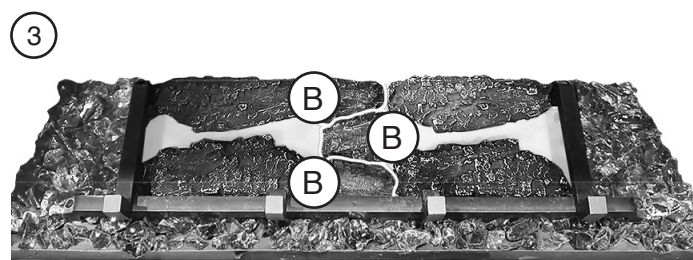
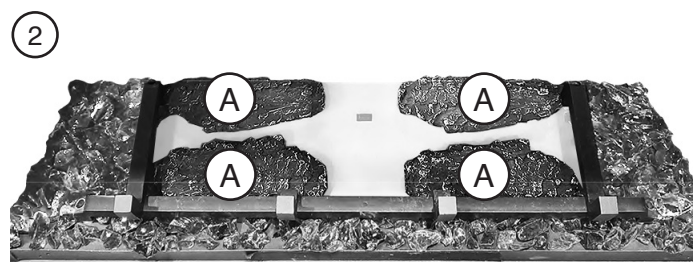
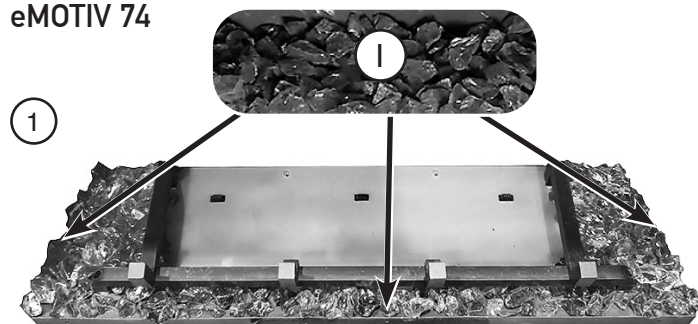

- GB:** Place Glass Embers (H) evenly with white sides facing up.
- FR:** Disposez les Braises De Verre (H) uniformément, les faces blanches vers le haut.
- DE:** Glasglut (H) gleichmäßig mit der weißen Seite nach oben platzieren.
- NL:** Plaats Glazen Sintels (H) gelijkmatig met witte kanten naar boven gericht.
- IT:** Disporre le Ciochi In Vetro (H) in modo uniforme con i lati bianchi rivolti verso l'alto.
- NO:** Plasser Glassglør (H) jevnt med de hvite sidene vendt opp.
- ES:** Distribuya uniformemente las Brasas De Vidrio (H) con las caras blancas mirando hacia arriba.
- GR:** Τοποθετήστε τα Διακοσμητικά Καρβουνα (H) ομοιόμορφα με τη λευκή πλευρά προς τα πάνω.
- LV:** Stikla Ogles (H) vienmērīgi novietojiet ar balto pusi uz augšu.
- LU:** Glasglous (H) tolygiai paskleiskite baltajā pusē j viršū.
- PT:** Coloque as Brasas Em Vidro (H) de forma uniforme com os lados brancos virados para cima.

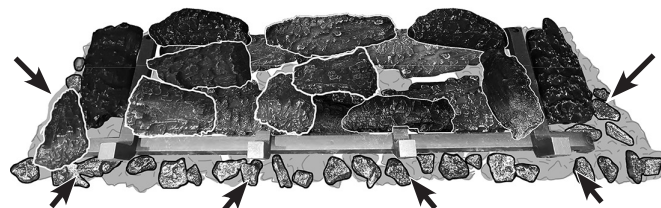

8

GB: Apply adhesive tape to logs at white dot positions

FR: Appliquez du ruban adhésif sur les bûches à l'emplacement des points blancs.

DE: Bringen Sie Klebeband an den weißen Punkten auf den Holzscheiten an.

NL: Breng klevende tape aan op de witte stippen op de houtblokken.

IT: Applicare il nastro adesivo ai ceppi in corrispondenza dei punti bianchi.

NO: Bruk teip på vedkubber i posisjonene med hvite prikker.

ES: Aplique cinta adhesiva a los troncos en las posiciones de los puntos blancos.

GR: Εφαρμόστε κολλητική ταινία στα κούτσουρα εκεί που είναι οι λευκές βούλες.

LV: Uzlīmējiet līmlenti uz pagalēm balto punktu vietās.

LU: Ant rāstų baltų taškų vietose užklijuokite lipniąją juosta.

PT: Aplique fita adesiva nos troncos, nos locais com pontos brancos.

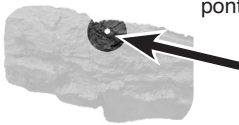

12

GB: Adhesive Tape

FR: Ruban adhésif

DE: Klebeband

NL: Klevend tape

IT: Nastro adesivo

NO: Teip

ES: Cinta adhesiva

GR: Κολλητική ταινία

LV: Līmlente

LU: Lipnioji juosta

PT: Fita adesiva

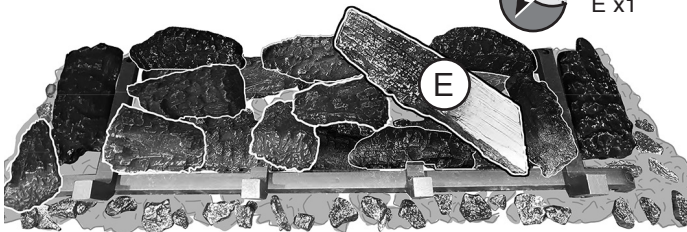

13

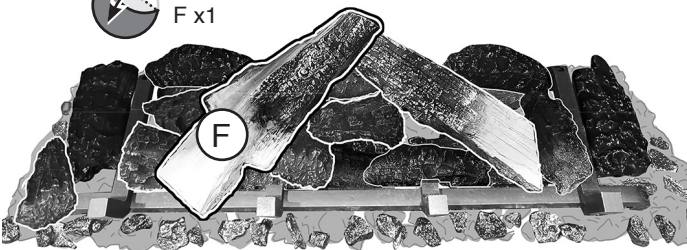

14

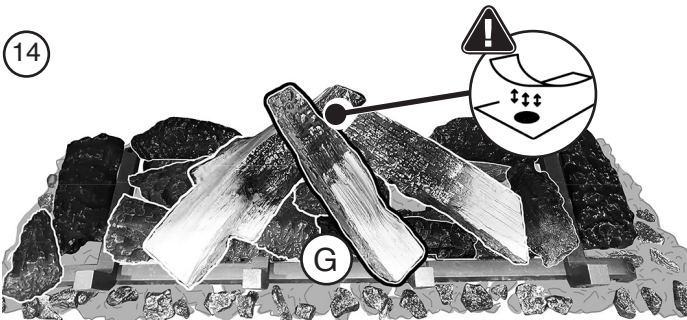

15

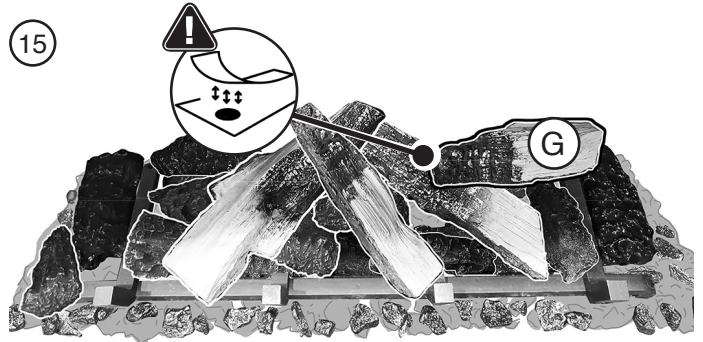

16

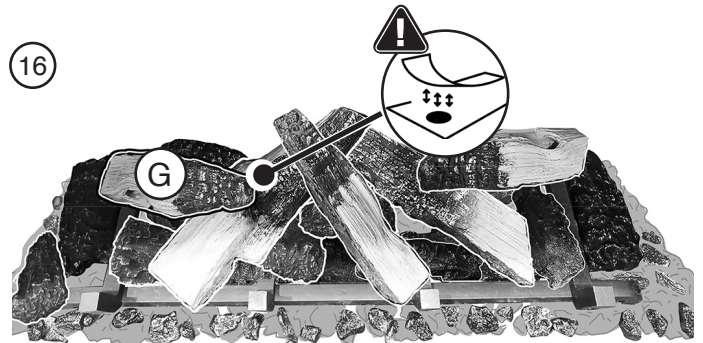

17



eMOTIV 84

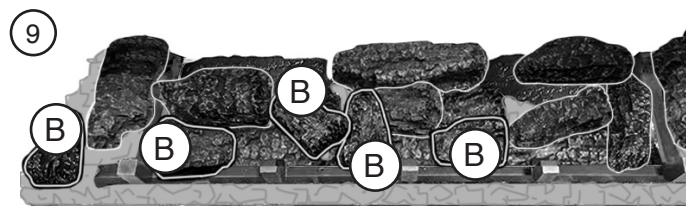
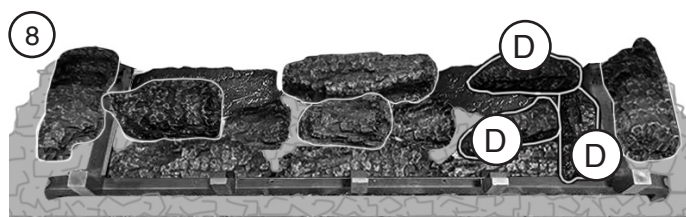
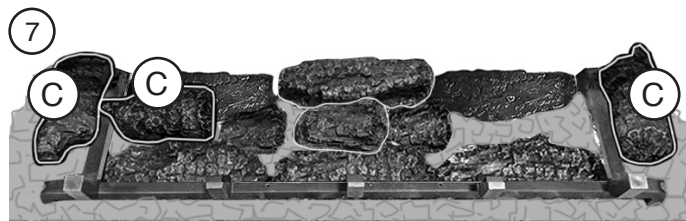
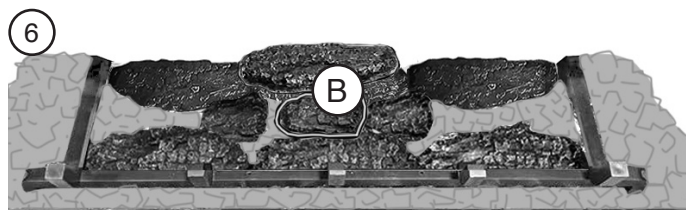
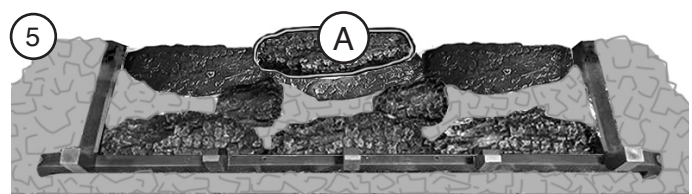
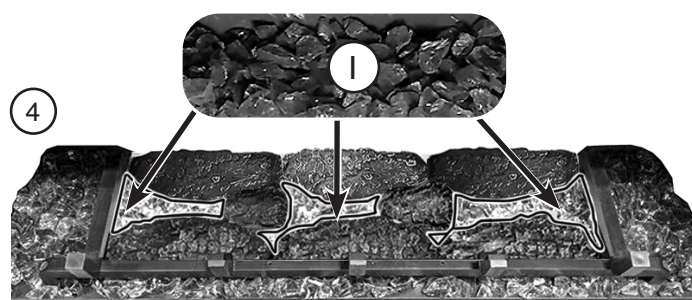
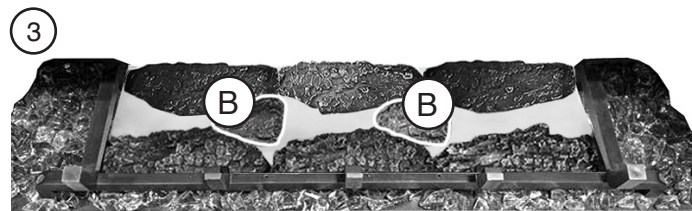
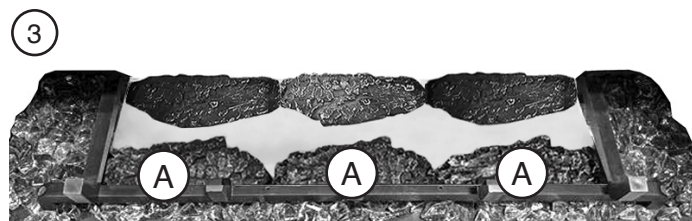
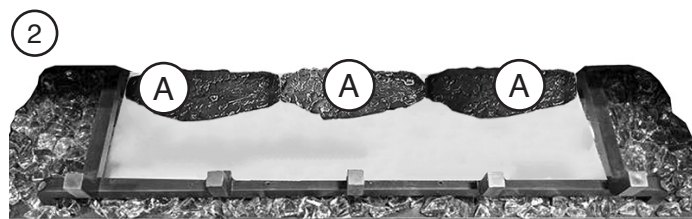
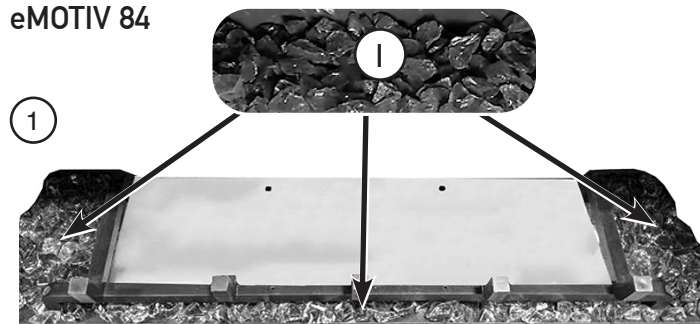

10

GB: Place Glass Embers (H) evenly with white sides facing up.
FR: Disposez les Braises De Verre (H) uniformément, les faces blanches vers le haut.

DE: Glasglut (H) gleichmäßig mit der weißen Seite nach oben platzieren.

NL: Plaats Glazen Sintels (H) gelijkmatig met witte kanten naar boven gericht.

IT: Disporre le Ciocchi In Vetro (H) in modo uniforme con i lati bianchi rivolti verso l'alto.

NO: Plasser Glassglør (H) jevnt med de hvite sidene vendt opp.

ES: Distribuya uniformemente las Brasas De Vidrio (H) con las caras blancas mirando hacia arriba.

GR: Τοποθετήστε τα Διακοσμητικά Καρβουνα (H) ομοιόμορφα με τη λευκή πλευρά προς τα πάνω.

LV: Stikla Ogles (H) vienmērīgi novietojiet ar balto pusi uz augšu.

LU: Glasglous (H) tolygiai paskleiskite baltaja puse ģ viršu.

PT: Coloque as Brasas Em Vidro (H) de forma uniforme com os lados brancos virados para cima.

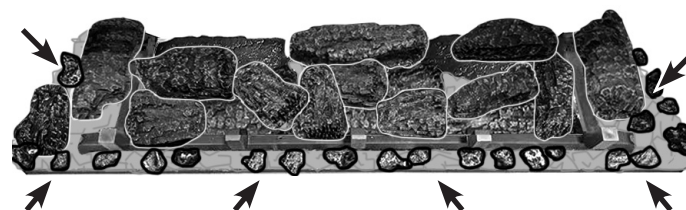

8

GB: Apply adhesive tape to logs at white dot positions

FR: Appliquez du ruban adhésif sur les bûches à l'emplacement des points blancs.

DE: Bringen Sie Klebeband an den weißen Punkten auf den Holzscheiten an.

NL: Breng klevende tape aan op de witte stippen op de houtblokken.

IT: Applicare il nastro adesivo ai ceppi in corrispondenza dei punti bianchi.

NO: Bruk teip på vedkubber i posisjonene med hvite prikker.

ES: Aplique cinta adhesiva a los troncos en las posiciones de los puntos blancos.

GR: Εφαρμόστε κολλητική ταινία στα κούτσουρα εκεί που είναι οι λευκές βούλες.

LV: Uzlīmējiet līmlenti uz pagalmē balto punktu vietās.

LU: Ant raštų baltų taškų vietose užklijuokite lipniąją juosta.

PT: Aplique fita adesiva nos troncos, nos locais com pontos brancos.

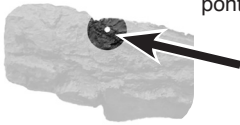

12

GB: Adhesive Tape

FR: Ruban adhésif

DE: Klebeband

NL: Klevend tape

IT: Nastro adesivo

NO: Teip

ES: Cinta adhesiva

GR: Κολλητική ταινία

LV: Līmlente

LU: Lipnioji juosta

PT: Fita adesiva

F x3

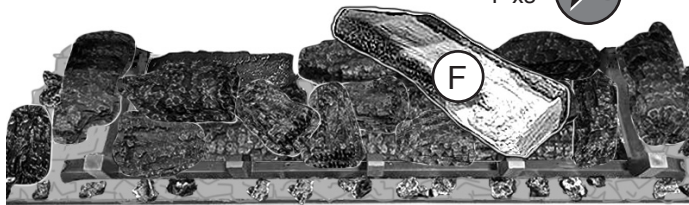

13

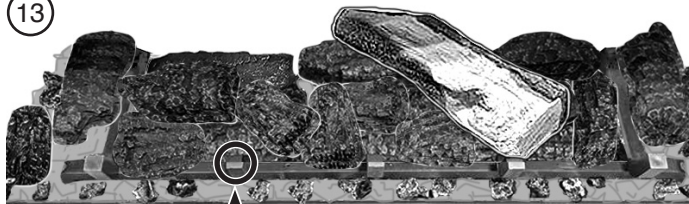

GB: Adhesive Tape x1

FR: Ruban adhésif x1

DE: Klebeband x1

NL: Klevend tape x1

IT: Nastro adesivo x1

NO: Teip x1

ES: Cinta adhesiva x1

GR: Κολλητική ταινία x1

LV: Līmlente x1

LU: Lipnioji juosta x1

PT: Fita adesiva x1

14

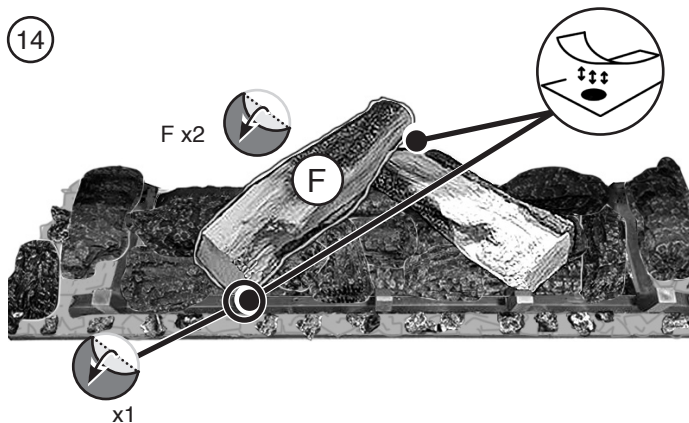

15

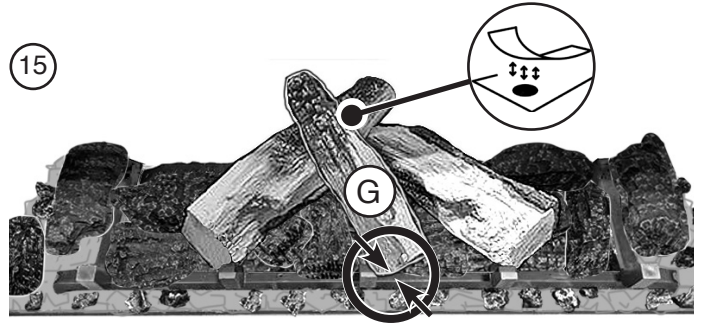

16

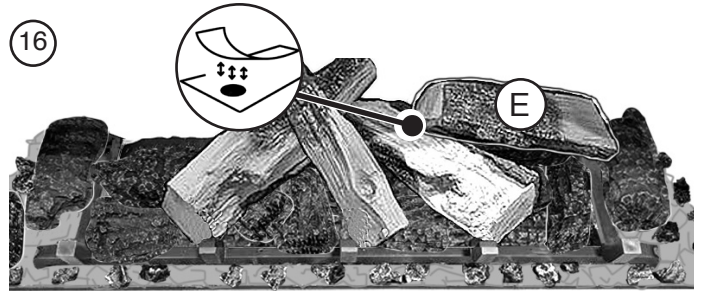

17

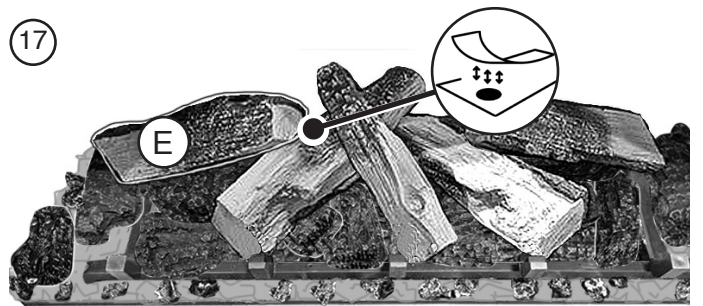

18



GB: REMOVING THE FUEL BED

FR: DÉPOSE DU LIT DE COMBUSTIBLE

DE: ENTFERNEN DES BRENNSTOFFBETTS

NL: BRANDSTOFBED VERWIJDEREN

IT: SMONTAGGIO DEL CROGIOLO DI COMBUSTIONE

NO: SLIK FJERNER DU BRENNKAMMERET

ES: EXTRACCIÓN DEL LECHO DE COMBUSTIBLE

GR: ΑΦΑΙΡΕΣΗ ΤΗΣ ΚΛΙΝΗΣ ΚΑΥΣΙΜΟΥ

LV: DEGOŠĀ SLĀŅA IZŅEMŠANA

LU: BRENNSTOFFBETT ERAUSHUELEN

PT: REMOÇÃO DO LEITO DE COMBUSTÍVEL

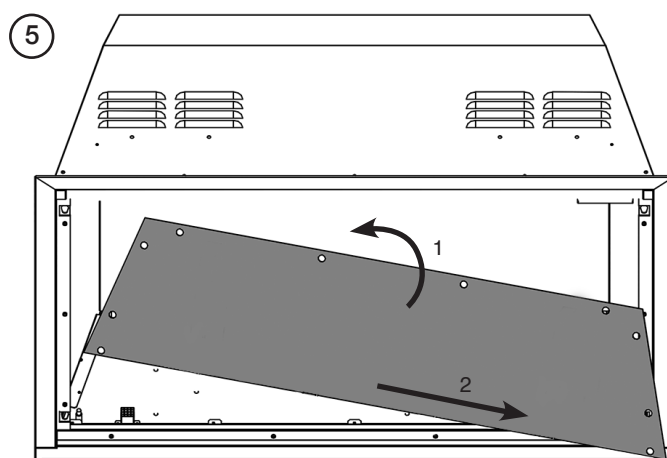
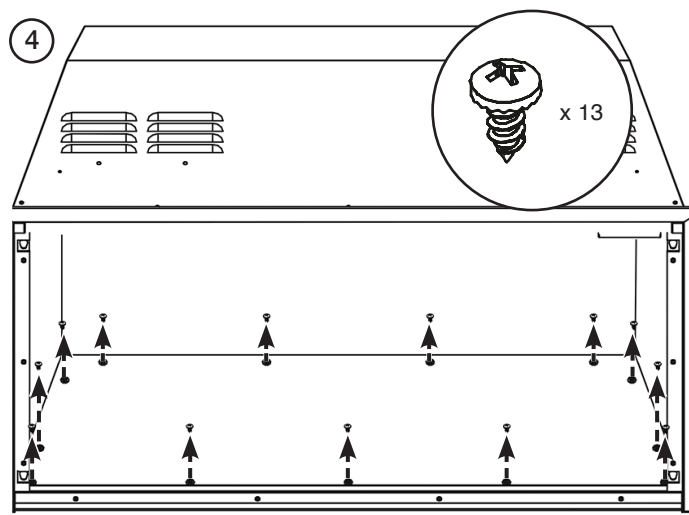
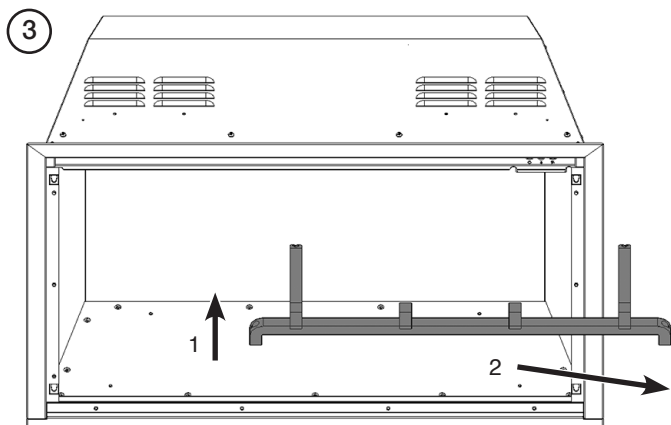
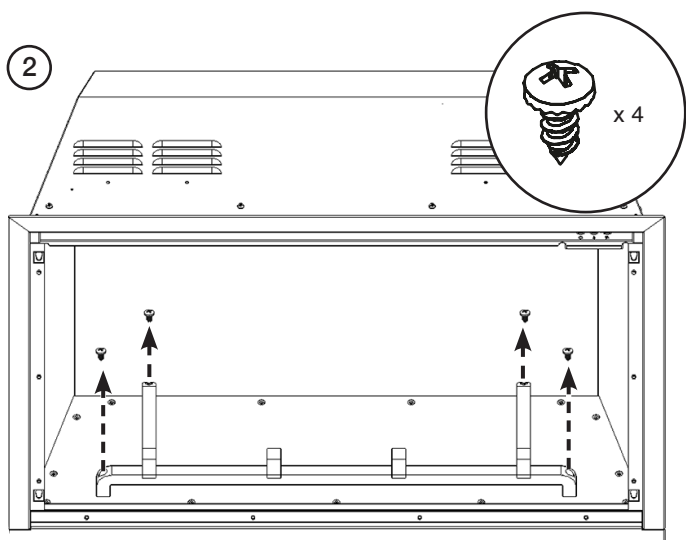
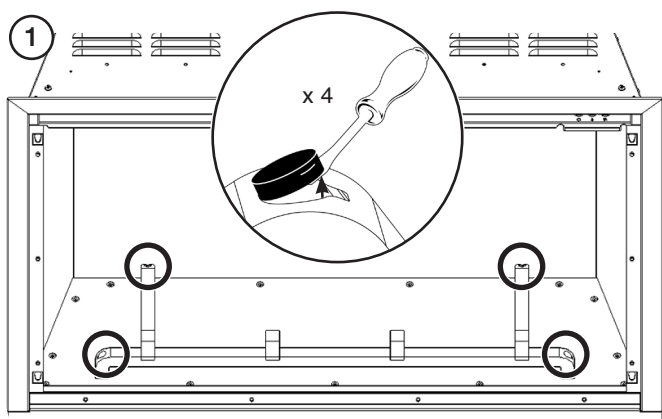

GB: REPLACING THE FUEL BED LEDS
 FR: REMPLACEMENT DU LIT DE COMBUSTIBLE
 PANNEAUX À LED
 DE: AUSTAUSCHEN DER BRENNSTOFFBETT
 LED-PLATINEN
 NL: BRANDSTOFBED VERVANGEN LED-PANELEN
 IT: SOSTITUZIONE DEL CROGIOLO DI COMBUSTIONE
 PANNELLI DI LED
 NO: SLIK BYTTER DU BRENNKAMMERET
 LED-TAVLER

ES: REEMPLAZO DEL LECHO DE COMBUSTIBLE
 PANELES LED
 GR: ΑΝΤΙΚΑΤΑΣΤΑΣΗ ΠΛΑΚΕΤΩΝ LED ΣΤΗΝ ΚΛΙΝΗ
 ΚΑΥΣΙΜΟΥ
 LV: DEGOŠĀ SLĀŅA NĀMAINĪŠANA LED DĒĻI
 LU: BRENNSTOFFBETT ERĒM ASETZEN LED-
 PLACKEN
 PT: SUBSTITUIÇÃO DO LEITO DE COMBUSTÍVEL
 PLACAS DE LED

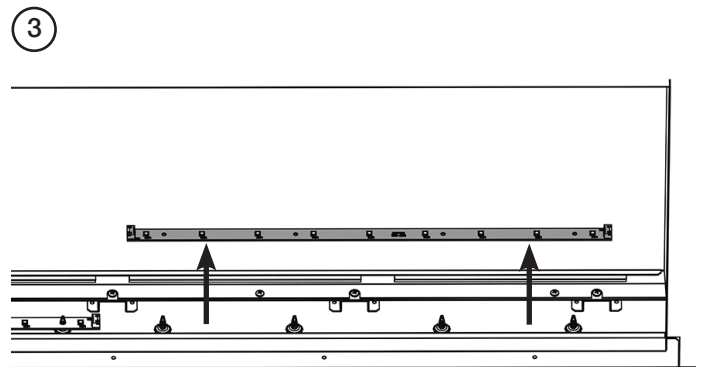
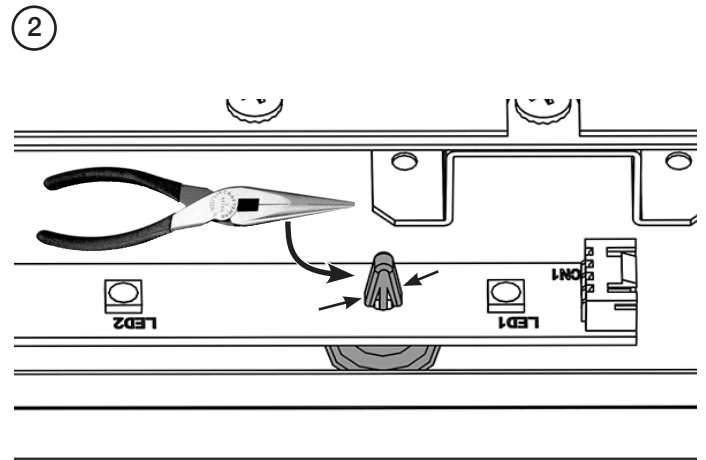
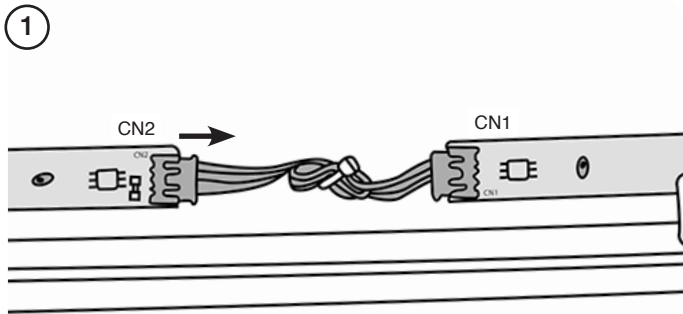
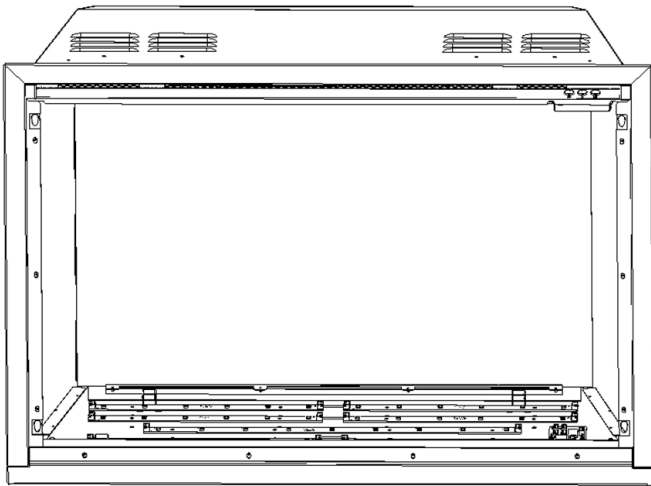

GB: REMOVING THE LED LIGHT BAR

FR: RETIRER LA BARRE À LED

DE: LED-LICHTLEISTE ENTFERNEN

NL: DE LED-LICHTBALK VERWIJDEREN

IT: RIMOZIONE DELLA BARRA LUMINOSA A LED

NO: TA UT LED-LYSBJELKEN

ES: EXTRACCIÓN DE LA BARRA DE LUZ LED

GR: ΑΝΤΙΚΑΤΑΣΤΑΣΗ ΤΗΣ ΒΑΡΔΟΥ ΦΩΤΙΣΜΟΥ LED

LV: LED GAISMAS JOSLAS NOŅEMŠANA

LU: EWECHHUELE VUN DER LED-LUUCHTLÄISCHT

PT: REMOÇÃO DA BARRA DE LUZ LED

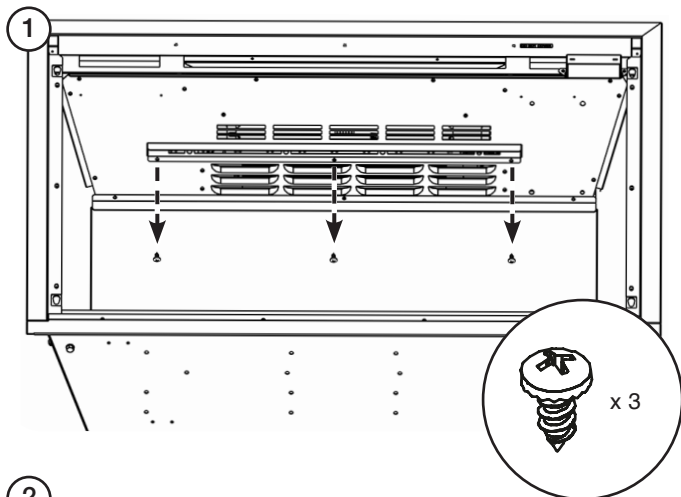

2

GB: Disconnect the wire from the LED board.

FR: Débranchez le câble du panneau à LED.

DE: Trennen Sie das Kabel von der LED-Platine.

NL: Ontkoppel de kabel van het LED-bord.

IT: Scollegare il cavo dalla scheda LED.

NO: Koble fra ledningen fra LED-kortet.

ES: Desconecte el cable de la placa de LED.

GR: Αποσυνδέστε το καλώδιο από την πλακέτα LED.

LV: Atvienojiet vadu no LED paneļa.

LU: Trennt den Drot vum LED Board.

PT: Desconecte o fio da placa de LED.

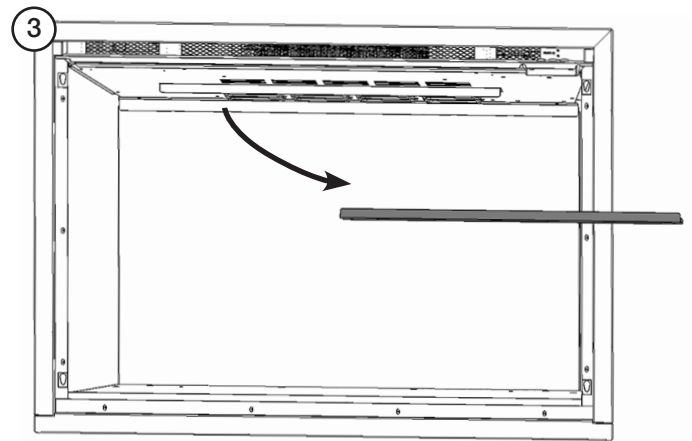
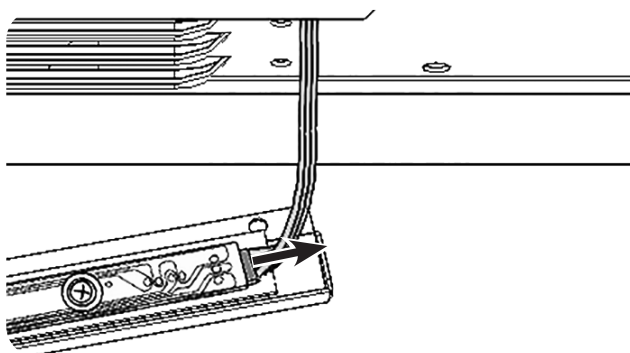

4

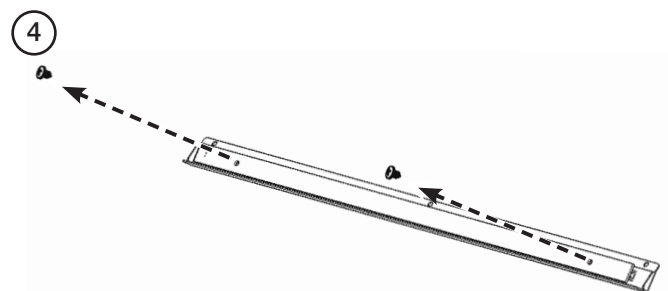

5

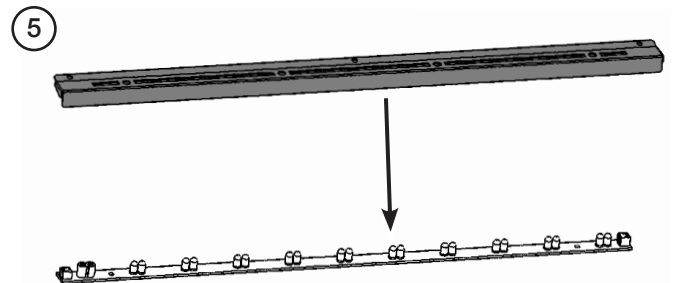

GB: BUTTON BOARD

FR: PANNEAU DE BOUTONS

DE: MANUELLES BEDIENFELD

NL: BEDIENINGPANEEL

IT: SCHEDA PULSANTI

NO: KNAPP-KORT

ES: PANEL DE BOTONES

GR: ΠΛΑΚΕΤΑ ΚΟΥΜΠΙΩΝ

LV: POGU PULTS

LU: SCHALTAFEL

PT: BOTÃO DA PLACA

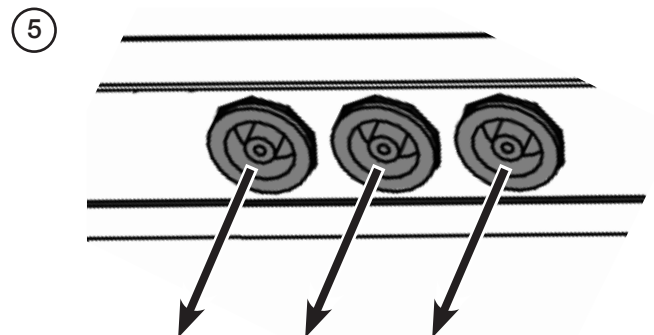
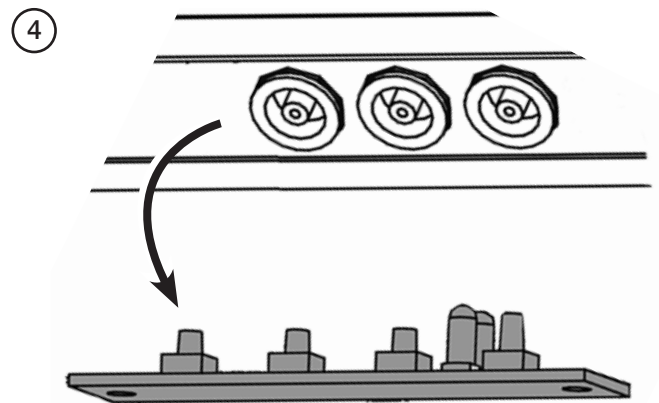
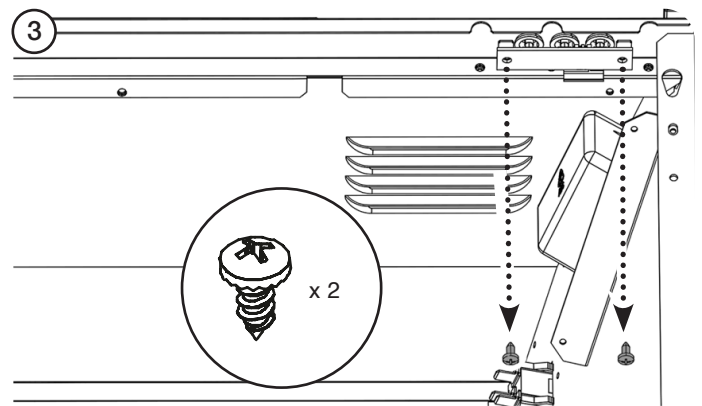
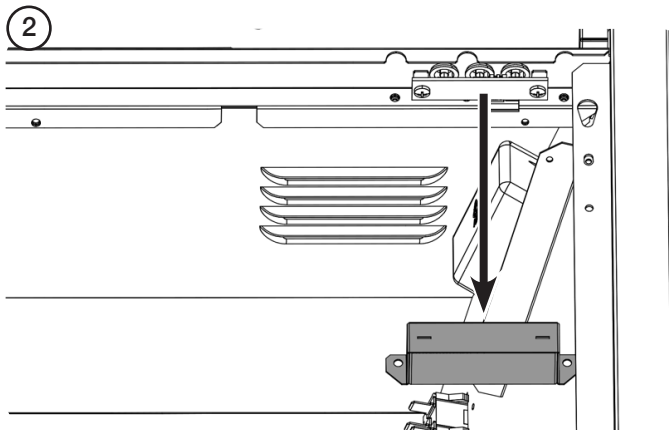
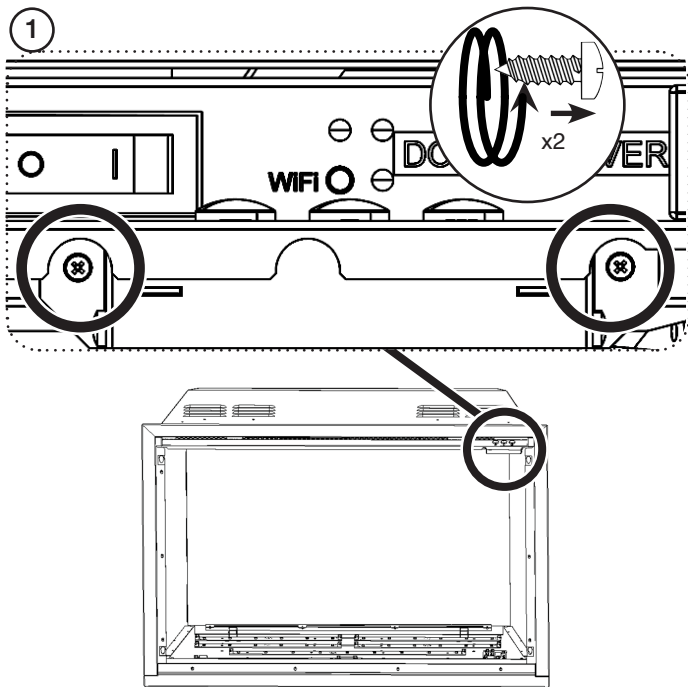

GB: REMOVING THE INNER SCREEN
 FR: RETRAIT DE L'ÉCRAN INTÉRIEUR
 DE: AUSBAU DER INNENBLENDE
 NL: BINNENSCHERM VERWIJDEREN
 IT: SMONTAGGIO DELLO SCHERMO INTERNO
 NO: SLIK FJERNER DU INNERSKJERMEN

ES: EXTRACCIÓN DE LA PANTALLA INTERNA
 GR: ΑΦΑΙΡΕΣΗ ΤΗΣ ΕΣΩΤΕΡΙΚΗΣ ΣΗΤΑΣ
 LV: IEKŠĒJĀ AIZSLIETŅA NOŅEMŠANA
 LU: DE BANNESCHTE BILDSCHIRM ERAUSHUELEN
 PT: REMOÇÃO DO ECRÃ INTERIOR

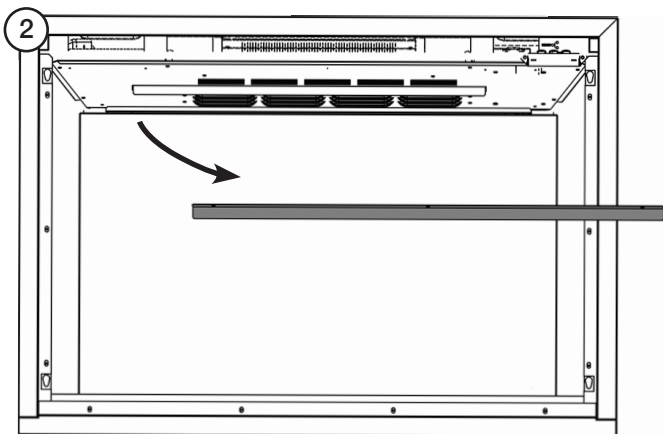
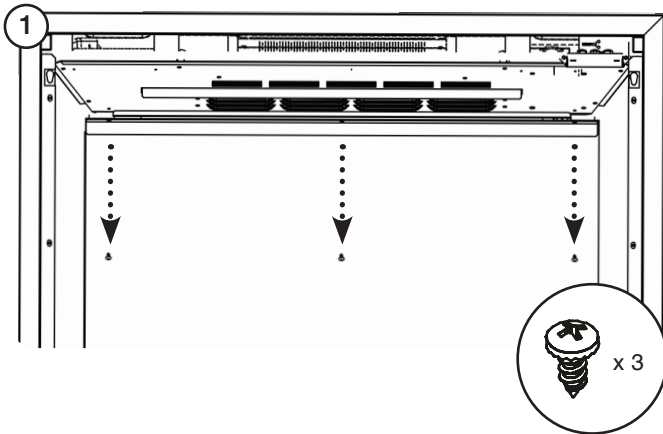

GB: Rear Glass
 FR: Vitre arrière
 DE: Hintere Scheibe
 NL: Glas achter
 IT: Vetro Posteriore
 NO: Bakglass
 ES: Cristal Posterior
 GR: Πίσω Γυαλί
 LV: Aizmugurējais Stikls
 LU: Galinis Stiklas
 PT: Vidro Traseiro

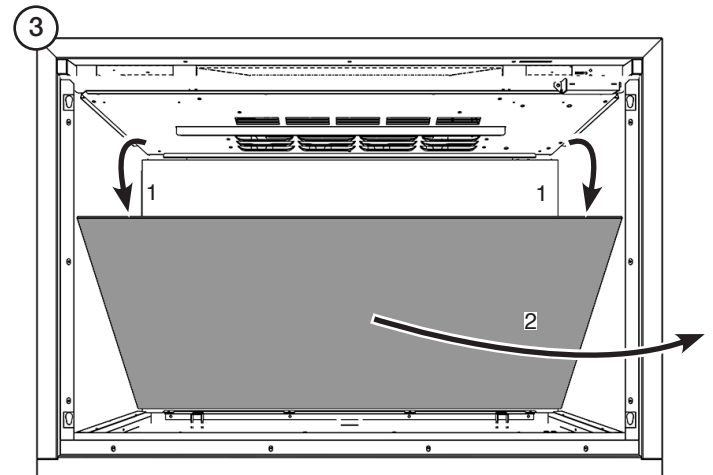

GB: Inner Screen
 FR: Écran Intérieur
 DE: Innenblende
 NL: Binnenscherm
 IT: Schermo Interno
 NO: Innerskjermen
 ES: Pantalla Interna
 GR: Εσωτερικής Σητας
 LV: Iekšējā Aizslietņ
 LU: Banneschte
 Bildschirm
 PT: Ecrã Interior

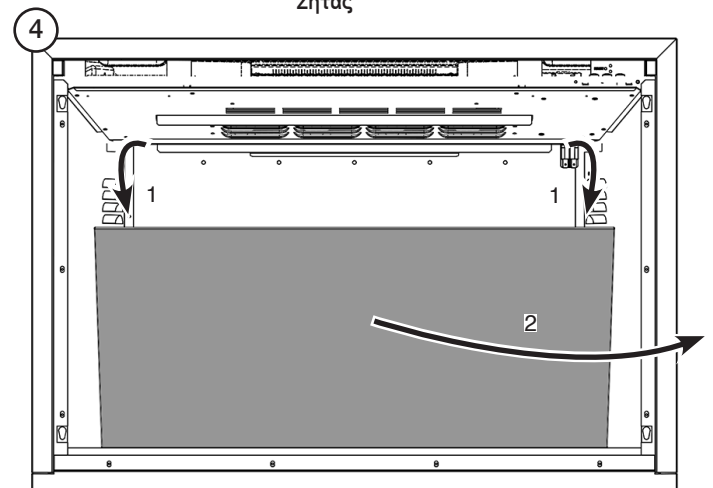

GB: REMOVING THE FLAME EFFECT
 FR: RETRAIT DE L'EFFET FLAMME
 DE: AUSBAU DES FLAMMENEFFEKTS
 NL: VLAMEFFECT VERWIJDEREN
 IT: DISATTIVAZIONE DEGLI EFFETTI FIAMMA
 NO: SLIK FJERNER DU FLAMMEEFFEKTEN

ES: EXTRACCIÓN DEL EFECTO DE LAS LLAMAS
 GR: ΑΦΑΙΡΕΣΗ ΤΟΥ ΕΦΕ ΦΛΟΓΑΣ
 LV: LIESMAS EFEKTA NOŅEMŠANA
 LU: DE FLAMENEFFEKT ERAUSHUELEN
 PT: DREMOÇÃO DO EFEITO DE CHAMA

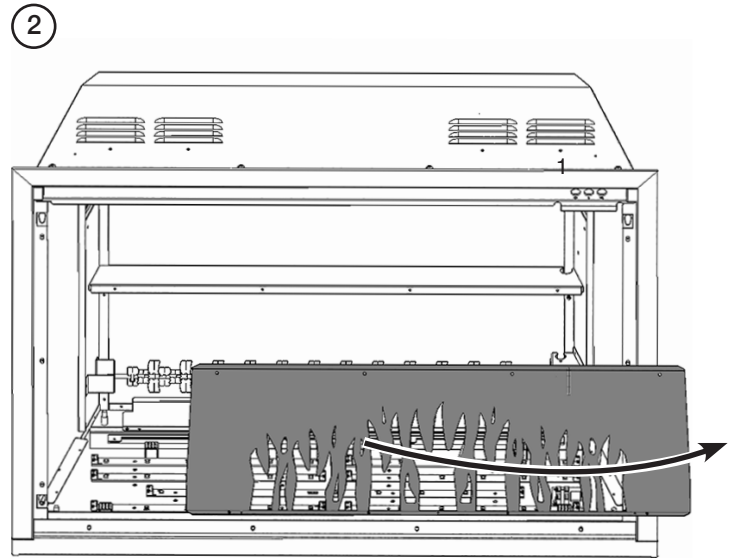
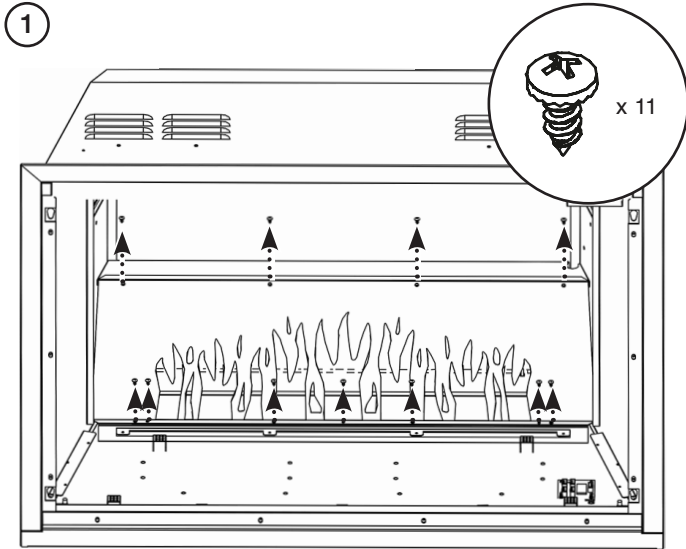

GB: REMOVING THE EFFECT SPINDLE
 FR: RETRAIT DE L'AXE DE L'EFFET
 DE: AUSBAU DER EFFEKTSPINDEL
 NL: EFFECTENAS VERWIJDEREN
 IT: SMONTAGGIO DELL'ECENTRICO DEGLI EFFETT
 NO: SLIK FJERNER DU EFFEKTHJULET

ES: EXTRACCIÓN DEL EJE DEL EFECTO
 GR: ΑΦΑΙΡΕΣΗ ΤΗΣ ΑΤΡΑΚΤΟΥ ΤΟΥ ΕΦΕ
 LV: EFEKTU VĀRPSTAS NOŅEMŠANA
 LU: D'EFFEKTSPÉNDEL ERAUSHUELEN
 PT: REMOÇÃO DO EFEITO DE FUSO

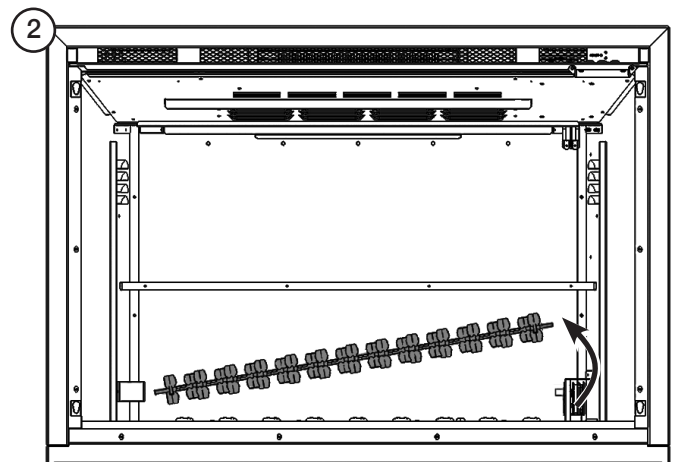
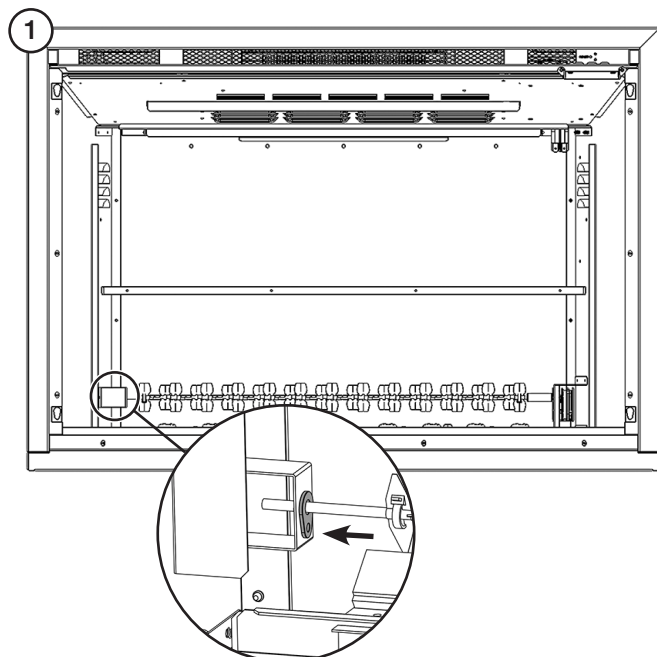

GB: REPLACING THE FLAME EFFECT LEDS
 FR: REMPLACEMENT DES LED DE L'EFFET FLAMME
 DE: AUSTAUSCHEN DER FLAMMENEFFEKT-LEDS
 NL: VLAMEFFECT-LEDS VERVANGEN
 IT: SOSTITUZIONE DEI LED DEGLI EFFETTI FIAMMA
 NO: SLIK BYTTER DU LED-FLAMMEEFFEKTEN

ES: REEMPLAZO DE LOS LED PARA EL EFECTO DE LAS LLAMAS
 GR: ANTIKATAΣΤΑΣΗ ΤΩΝ LED ΣΤΟ ΕΦΕ ΦΛΟΓΑΣ
 LV: LIESMAS EFEKTA LED SPULDŽU NOMAINĪŠANA
 LU: D'FLAMMENEFFEKT-LEDEN ERĒM ASETZEN
 PT: SUBSTITUIÇÃO DOS LEDS DE EFEITO DE CHAMA

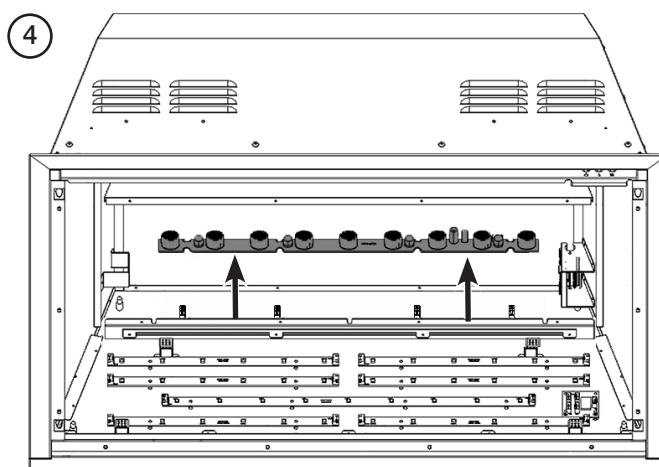
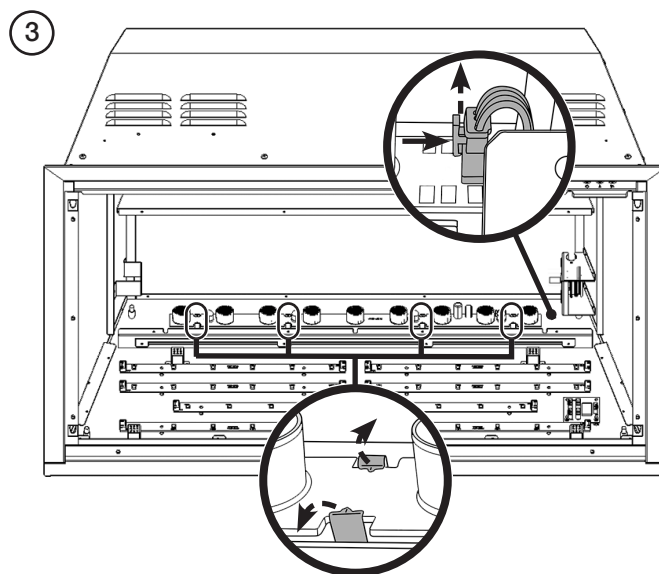
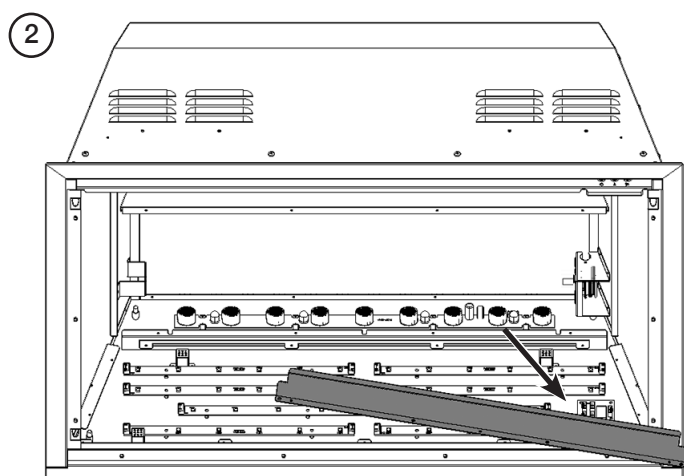
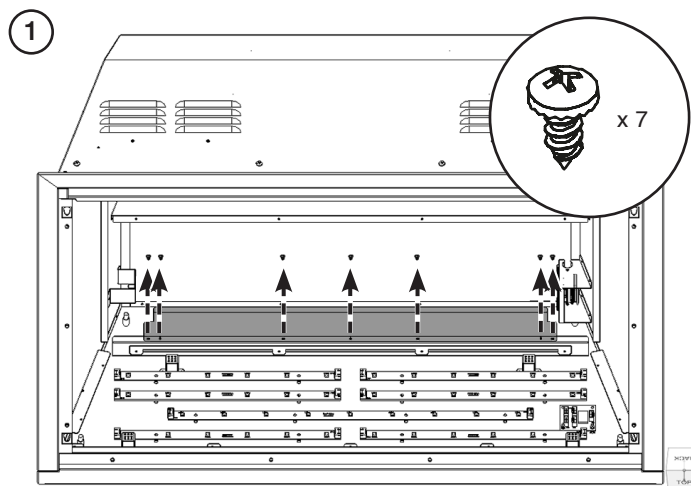

GB: REMOVING THE FLAME EFFECT MOTOR
 FR: RETRAIT DU MOTEUR DE L'EFFET FLAMME
 DE: ENTFERNEN DES FLAMMEEFFEKT-MOTORS
 NL: VLAMEFFECTMOTOR VERWIJDEREN
 IT: SMONTAGGIO DEL MOTORE DEGLI EFFETTI
 FIAMMA
 NO: SLIK FJERNER DU FLAMMEEFFEKT-MOTOREN

ES: EXTRACCIÓN DEL MOTOR PARA EL EFECTO DE
 LAS LLAMAS
 GR: ΑΦΑΙΡΕΣΗ ΤΟΥ ΜΟΤΕΡ ΣΤΟ ΕΦΕ ΦΛΟΓΑΣ
 ΕΛΕΓΧΟΥ
 LV: LIESMAS EFEKTA MOTORA NOŅEMŠANA
 LU: DE FLAMENEFFEKT MOTOR ERAUSHUELEN
 PT: REMOÇÃO DO MOTOR EFEITO DE CHAMA

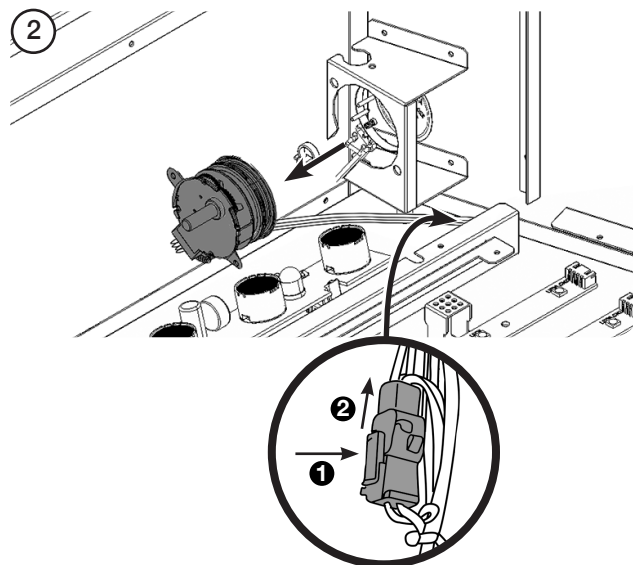
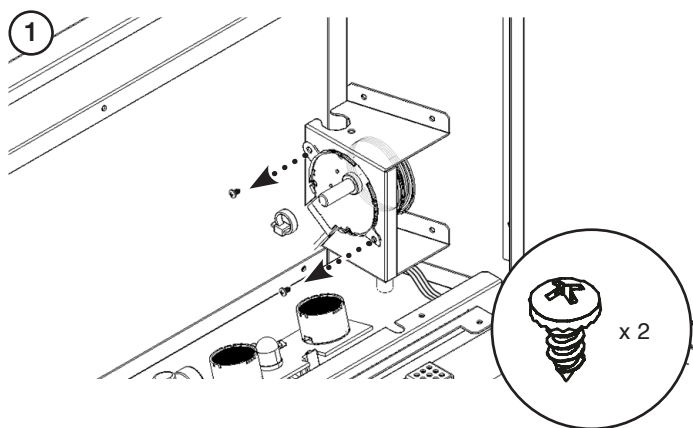

GB: REMOVING TOP BAFFLE

FR: DÉPOSE DU DÉFLECTEUR SUPÉRIEUR

DE: ENTFERNEN DER OBEREN ABDECKUNG

NL: VERWIJDERING BOVENSTE VLAMKERING

IT: RIMOZIONE DEL DEFLETTORE SUPERIORE

NO: FJERNING AV TOPPSKJERM

ES: EXTRACCIÓN DEL DEFLECTOR SUPERIOR

GR: ΑΦΑΙΡΕΣΗ ΤΟΥ ΠΑΝΩ ΔΙΑΦΡΑΓΜΑΤΟΣ

LV: AUGŠĒJĀ DEFLEKTORA NOŅEMŠANA

LU: VIRŠUTINĒS PERTVAROS NUĒMĪMAS

PT: REMOÇÃO DO DEFLETOR SUPERIOR

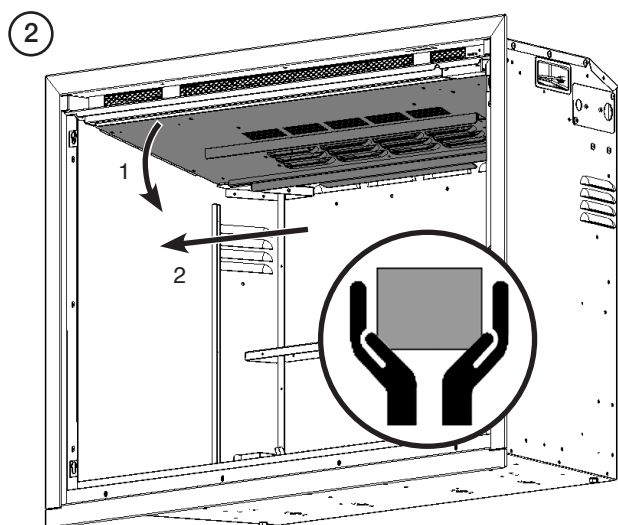
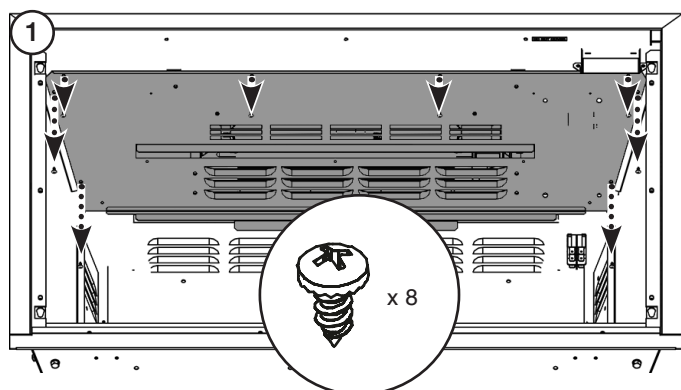
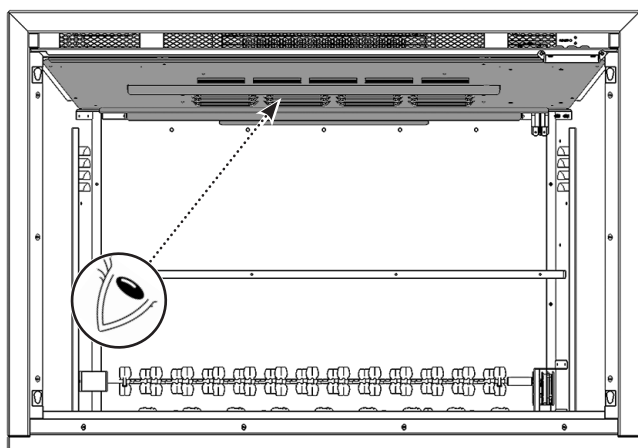

GB: Top Baffle flaps
FR: Rabat du déflecteur supérieur
DE: Obere Prallklappen
NL: Flappen bovenkant vlamkering
IT: Alette del deflettore superiore
NO: Øvre skjermklaffer

ES: Alas del deflector superior
GR: Πτερύγια πάνω διαφράγματος
LV: Augšējie deflektora atloki
LU: Viršutinās pertvaros atvartai
PT: Abas do defletor superior

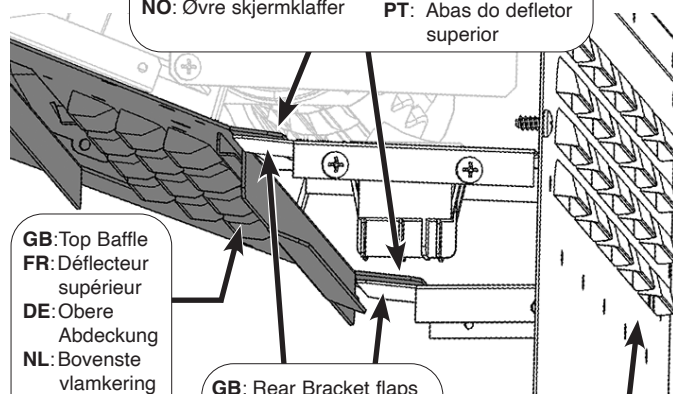

GB: Top Baffle
FR: Déflecteur supérieur
DE: Obere Abdeckung
NL: Bovenste vlamkering
IT: Deflettore superiore
NO: Toppskjerm
ES: Deflector superior
GR: Πάνω διάφραγμα
LV: Augšējais deflektors
LU: Viršutinā pertvara
PT: Defletor superior

GB: Rear Bracket flaps
FR: Rabats de la fixation arrière
DE: Halterungsklappen hinten
NL: Achterste beugelflappen
IT: Alette della staffa posteriore
NO: Bakre brakettklaffer
ES: Alas del soporte posterior
GR: Πτερύγια πίσω βραχίονα
LV: Aizmugurējā kronšteina atloki
LU: Galinio laikiklio atvartai
PT: Abas do suporte traseiro

GB: Rear of appliance
FR: Arrière de l'appareil
DE: Rückseite des Geräts
NL: Achterkant van apparaat
IT: Parte posteriore dell'apparecchio
NO: Baksiden av apparatet
ES: Parte trasera del aparato
GR: Πλάτη συσκευής
LV: Ierīces aizmugure
LU: Prietaiso galinė dalis
PT: Parte traseira do aparelho

3



GB: PCB

FR: CIRCUIT IMPRIMÉ

DE: PLATINE

NL: PRINTPLAAT

IT: PCB (SCHEDA A CIRCUITI STAMPATI)

NO: PCB

ES: PLACA PCI

GR: ΚΕΝΤΡΙΚΗ ΠΛΑΚΕΤΑ (PCB)

LV: PROGRAMMU VADĪBAS PULTS

LU: PCB

PT: PCB

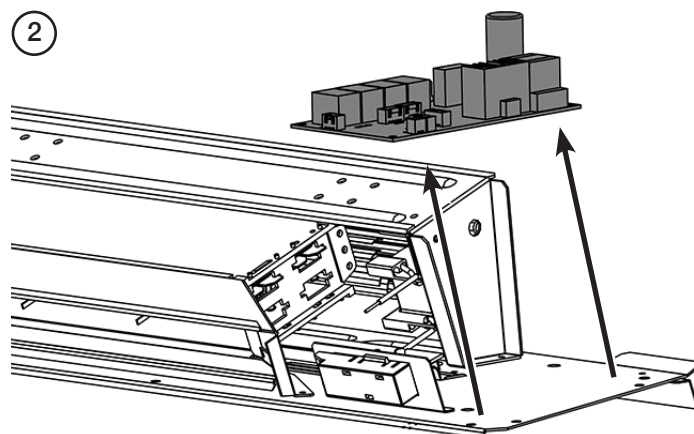
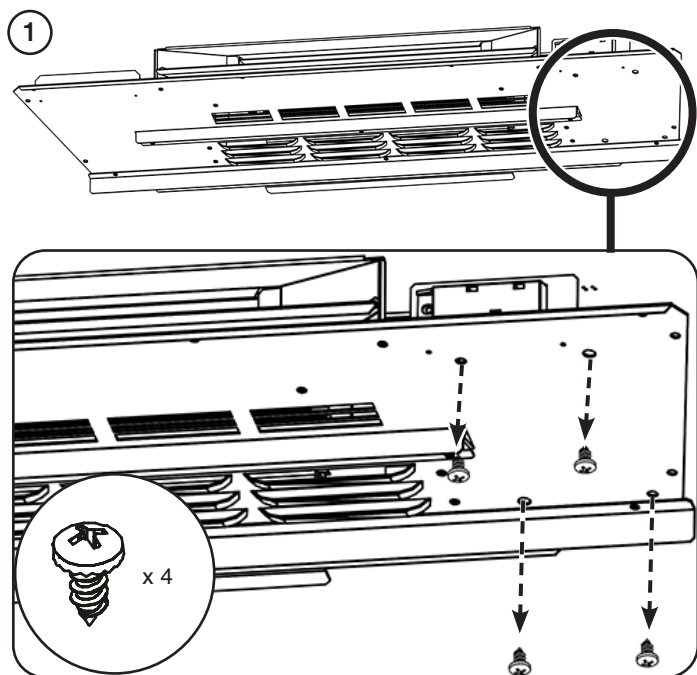

GB: REMOVING THE RECEIVER

FR: RETRAIT DU RÉCEPTEUR

DE: AUSBAU DES EMPFÄNGERS

NL: ONTVANGER VERWIJDEREN

IT: SMONTAGGIO DEL RICEVITORE

NO: SLIK FJERNER DU MOTTAKEREN

ES: XTRACCIÓN DEL RECEPTOR

GR: ΑΦΑΙΡΕΣΗ ΤΟΥ ΔΕΚΤΗ

LV: UZTVĒRĒJA NOŅEMŠANA

LU: DEN EMPFÄNGER ERAUSHUELEN

PT: REMOÇÃO DO RECETOR

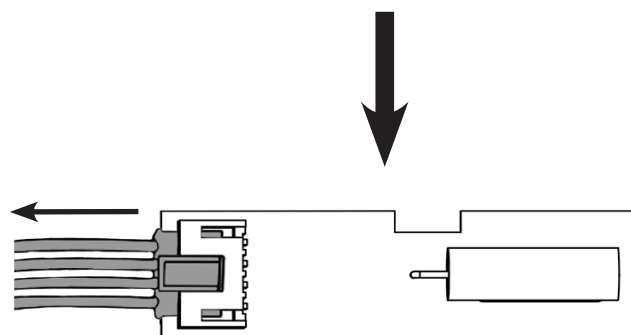
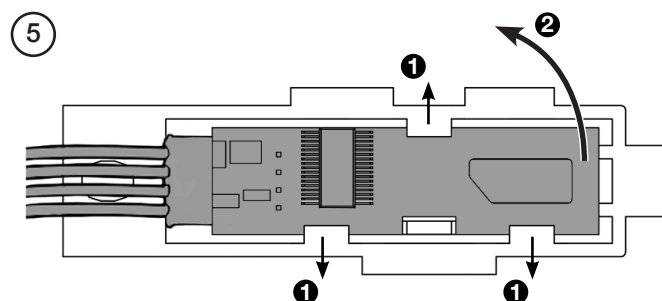
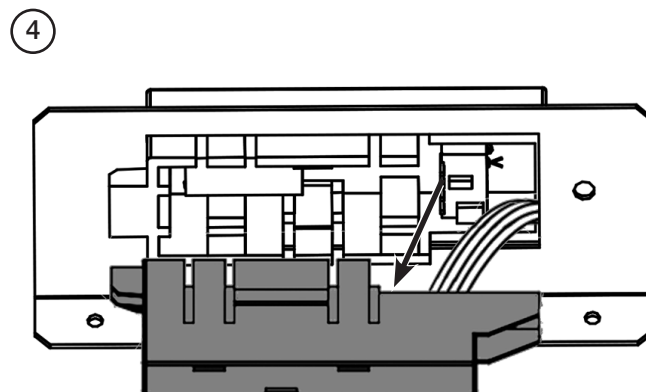
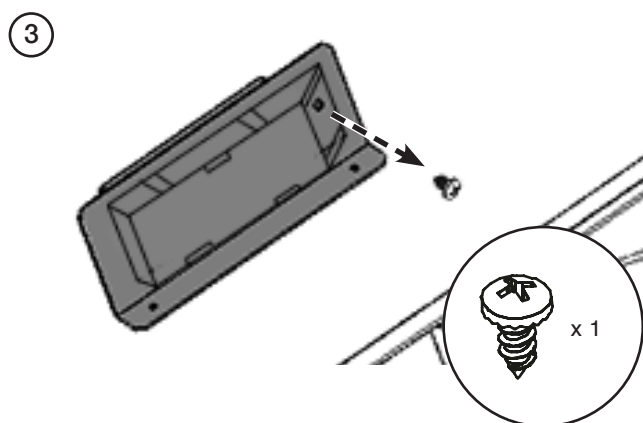
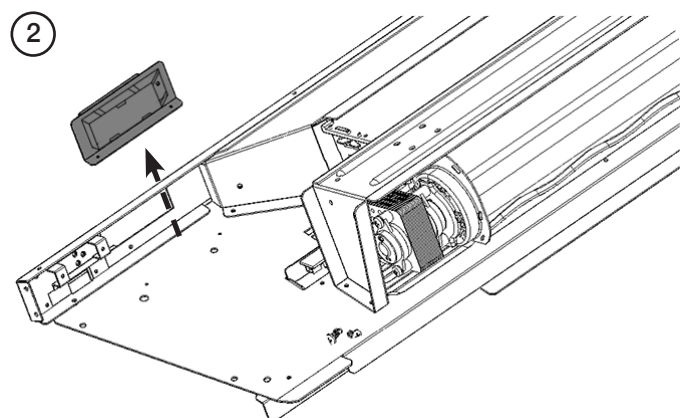
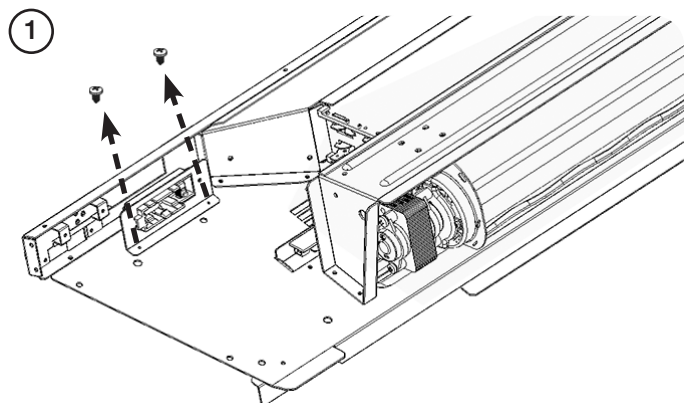

GB: REPLACING THE HEATER

FR: REMPLACEMENT DU CHAUFFAGE

DE: AUSTAUSCH DER HEIZUNG

NL: VERWARMINGSELEMENT VERVANGEN

IT: SOSTITUZIONE DEL RISCALDATORE

NO: SLIK FJERNER DU VARMEAPPARATET

ES: REEMPLAZO DEL CALEFACTOR

GR: ΑΝΤΙΚΑΤΑΣΤΑΣΗ ΤΟΥ ΘΕΡΜΑΝΤΙΚΟΥ ΣΤΟΙΧΕΙΟΥ

LV: SILDĪTĀJA NOMAINĪŠANA

LU: D'HEIZUNG ERĒM ASETZEN

PT: SUBSTITUIÇÃO DO AQUECEDOR

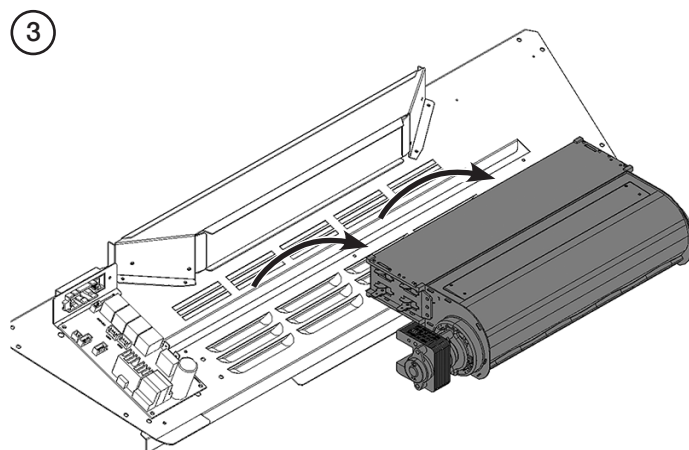
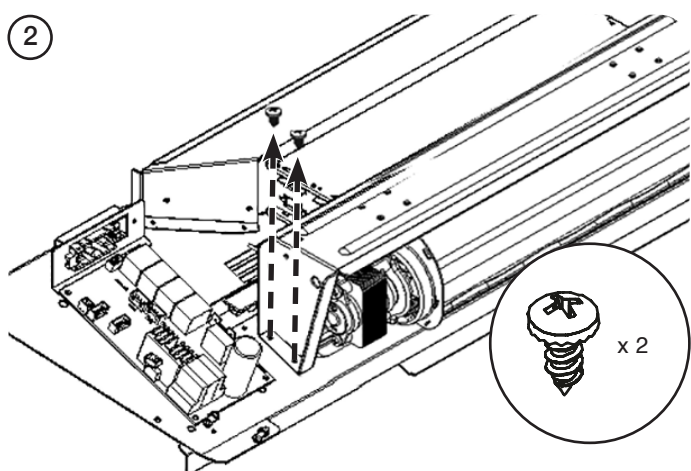
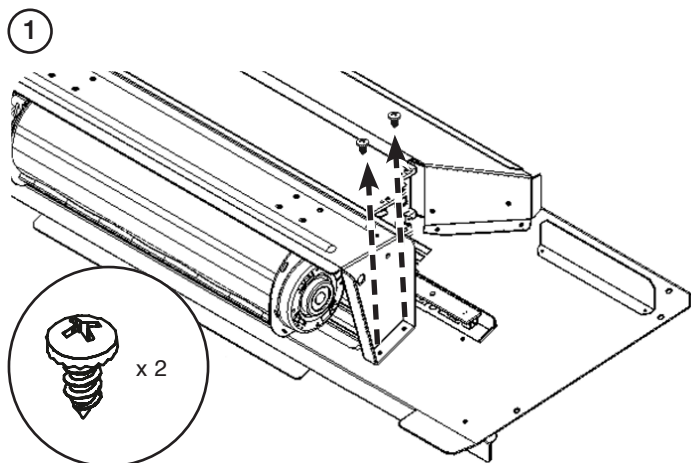

GB: WIRING DIAGRAM
 FR: PSCHÉMA DE CÂBLAGE
 DE: SCHALTPLAN
 NL: BEDRADINGSHEMA
 IT: SCHEMA DI CABLAGGIO
 NO: KOBLINGSDIAGRAM

ES: ESQUEMA DE CABLEADO
 GR: ΗΛΕΚΤΡΙΚΟ ΔΙΑΓΡΑΜΜΑ
 LV: ELEKTROINSTALĀCIJAS DIAGRAMMA
 LU: VERKABELUNGSDIAGRAMM
 PT: DIAGRAMA DE CABLAGEM

COLOUR CODES/ CODES COULEUR/ FARBCODES/ KLEURCODES/ CODICE COLORE/ FARGEKODER/ CÓDIGOS DE COLOR							
	ENGLISH	FRANÇAIS	DEUTSCHE	NEDERLANDS	ITALIANO	NORSK	ESPAÑA
RD	RED	ROUGE	ROT	ROOD	ROSSO	RØD	ROJO
BU	BLUE	BLEU	BLAU	BLAUW	BLU	BLÅ	AZUL
YE	YELLOW	JAUNE	GELB	GEEL	GIALLO	GUL	AMARILLO
WH	WHITE	BLANC	WEISS	WIT	BIANCO	HVIT	BLANCO
BK	BLACK	NOIR	SCHWARZ	ZWART	NERO	SVART	NEGRO
BN	BROWN	MARRON	BRAUN	BRUIN	MARRONE	BRUN	MARRÓN
GNYE	GREEN & YELLOW	VERT & JAUNE	GRÜN & GELB	GROEN & GEEL	VERDE E GIALLO	GRØNN OG GUL	VERDE AMARILLO

ΚΩΔΙΚΟΙ ΧΡΩΜΑΤΩΝ / KRĀSU KODI / FAARFCODEN/ CÓDIGOS DE COR				
	ΕΛΛΗΝΙΚΑ	LATVIEŠU	LĒTZEBUERGESH	PORTUGUÊS
RD	ΚΟΚΚΙΝΟ	SARKANA	ROUT	VERMELHO
BU	ΜΠΛΕ	ZILA	BLO	AZUL
YE	ΚΙΤΡΙΝΟ	DZELTENA	GIEL	AMARELO
WH	ΛΕΥΚΟ	BALTA	WÄISS	BRANCO
BK	ΜΑΥΡΟ	MELNA	SCHWAARZ	PRETO
BN	ΚΑΦΕ	BRŪNA	BRONG	CASTANHO
GNYE	ΠΡΑΣΙΝΟ & ΚΙΤΡΙΝΟ	ZĀLA UN DZĒLTENA	GRÉNG A GIEL	VERDE E AMARELO

GB: WIRING DIAGRAM
 FR: PSCHÉMA DE CÂBLAGE
 DE: SCHALTPLAN
 NL: BEDRADINGSHEMA
 IT: SCHEMA DI CABLAGGIO
 NO: KOBLINGSDIAGRAM

ES: ESQUEMA DE CABLEADO
 GR: ΗΛΕΚΤΡΙΚΟ ΔΙΑΓΡΑΜΜΑ
 LV: ELEKTROINSTALĀCIJAS DIAGRAMMA
 LU: VERKABELUNGSDIAGRAMM
 PT: DIAGRAMA DE CABLAGEM

NO.	ENGLISH	FRANÇAIS	DEUTSCHE	NEDERLANDS	ITALIANO	NORSK
1	LED Board RC07-283A	Panneau à LED RC07-283A	LED-Platine RC07-283A	LED-paneel RC07-283A	Pannello LED	LED-kort
2	Fan Motor	Moteur du ventilateur	Gebläsemotor	Ventilatoreenheid	Motore ventola	Motore ventola
3	Heater	Élément chauffant	Heizung	Verwarmingselement	Elemento del riscaldatore	Varmeelement
4	Receiver Board	Panneau du récepteur	Empfängerplatine	Ontvangstpaneel	Ricevitore	Mottager-kort
5	WiFi Board RC02-084A	WiFi - Panneau RC02-084A	WLAN - Platine RC02-084A	WiFi - paneel RC02-084A	WiFi- Pannello RC02-084A	WiFi - kort RC02-084A
6	Button Board RC02-041A	Panneau de boutons RC02-041A	Manuelles Bedienfeld RC02-041A	Knoppenpaneel RC02-041A	Scheda pulsanti RC02-041A	Knapp-kort RC02-041A
7	WiFi Receiver Board RC05-015A	WiFi - Panneau du récepteur RC05-015A	WLAN - Empfängerplatine RC05-015A	WiFi - Ontvangstpaneel RC05-015A	WiFi - Ricevitore RC05-015A	WiFi - Mottager-kort RC05-015A
8	Switch AC250V 16A	interrupteur-AC250V 16A	Schalter AC250V 16A	Schakelaar AC250V 16A	Interruttore AC250V 16A	Bryter AC250V 16A
9	Flame Motor	Moteur De Flammes	Flammenmotor	Brandmotor	Motore Della Fiamma	Flammemotor
10	Power Cable	Câble D'alimentation	Stromkabel	Voedingskabel	Cavo Di Alimentazione	Strømkabel
11	LED Board RC07-288A (Total 8 pcs)	Panneau à LED RC07-288A (total de 8)	LED-Platine RC07-288A (insgesamt 8 Stück)	LED-paneel RC07-288A (totaal 8)	Pannello LED RC07-288A (totale 8 pezzi)	LED-kort RC07-288A (totalt 8)
12	LED board RC07-191D (Total 1 pcs)	Panneau à LED RC07-191D (total de 1)	LED-Platine RC07-288A (insgesamt 1 Stück)	LED-paneel RC07-288A (totaal 1)	Pannello LED RC07-288A (totale 1 pezzo)	LED-kort RC07-288A (totalt 1)

NO.	ESPAÑA	ΕΛΛΗΝΙΚΑ	LATVIEŠU	LÉTZEBUGESCH	PORTUGUÉS
1	Placa de LED RC07-283A	Πλακέτα LED RC07-283A	LED plate RC07-283A	Šviesos diodų plokštė RC07-283A	Placa LED RC07-283A
2	Motor del ventilador	Μοτέρ ανεμιστήρα	Ventilatoreenheid	Lüftermotor	Motor da ventoinha
3	Calentador	Θερμαντικό στοιχείο	Verwarmingselement	Heizung	Aquecedor
4	Tablero receptor	Πλακέτα του δέκτη	Ontvangstpaneel	Empfängerplatinn	Placa do recetor
5	WiFi - Placa RC07-283A	WiFi - Πλακέτα RC07-283A	WiFi - plate RC07-283A	Wi-Fi- plokštė RC07-283A	WiFi - Placa RC07-283A
6	Tablero de botones	Πλακέτα κουμπιών	Knoppenpaneel	Schalttafel	Botão da placa
7	WiFi - Tablero receptor RC05-015A	WiFi - Πλακέτα του δέκτη RC05-015A	WiFi - Ontvangstpaneel RC05-015A	Wi-Fi - Empfängerplatinn RC05-015A	WiFi - Placa do recetor RC05-015A
8	interruptor AC250V 16A	διακόπτης AC250V 16A	Slēdzis AC250V	Schalter AC250V	Interruptor AC250V
9	Motor De Llamas	Μοτέρ Φλόγας	Liesmas Motors	Liepsnos Variklis	Motor De Chama
10	Cable De Alimentación	Καλώδιο Τροφοδοσίας	Barošanas Kabelis	Maitinimo Kabelis	Cabo De Alimentação
11	Placa de LED RC07-288A (8piezas en total)	Πλακέτα LED RC07-288A (συνολικά 8 κομμάτια)	LED plate RC07-288A (kopā 8 gab)	Šviesos diodų plokštė RC07-288A (iš viso 8 vnt.)	Placa LED RC07-288A (total de 8 peças)
12	Placa de LED RC07-191D (1 pieza en total)	Πλακέτα LED RC07-191D (συνολικά 1 κομμάτια)	LED plate RC07-191D (kopā 1 gab)	Šviesos diodų plokštė RC07-191D (iš viso 1 vnt.)	Placa LED RC07-191D (total de 1 peça)

GB: SPARE PARTS LIST

FR: LISTE DES PRINCIPALES PIÈCES DE RECHANGE

DE: ERSATZTEILLISTE

NL: LIJST STANDAARD RESERVE ONDERDELEN

IT: LISTINO PREZZI DEI RICAMBI

NO: RESERVEDELSLISTE

ES: RELACIÓN DE REPUESTOS

GR: ΚΑΤΑΛΟΓΟΣ ΑΝΤΑΜΑΚΤΙΚΩΝ

LV: VREZERVES DAĻU SARAKTS

LU: ERSATZDEELERLËSCHT

PT: LISTA DE PEÇAS SOBRESSELENTES

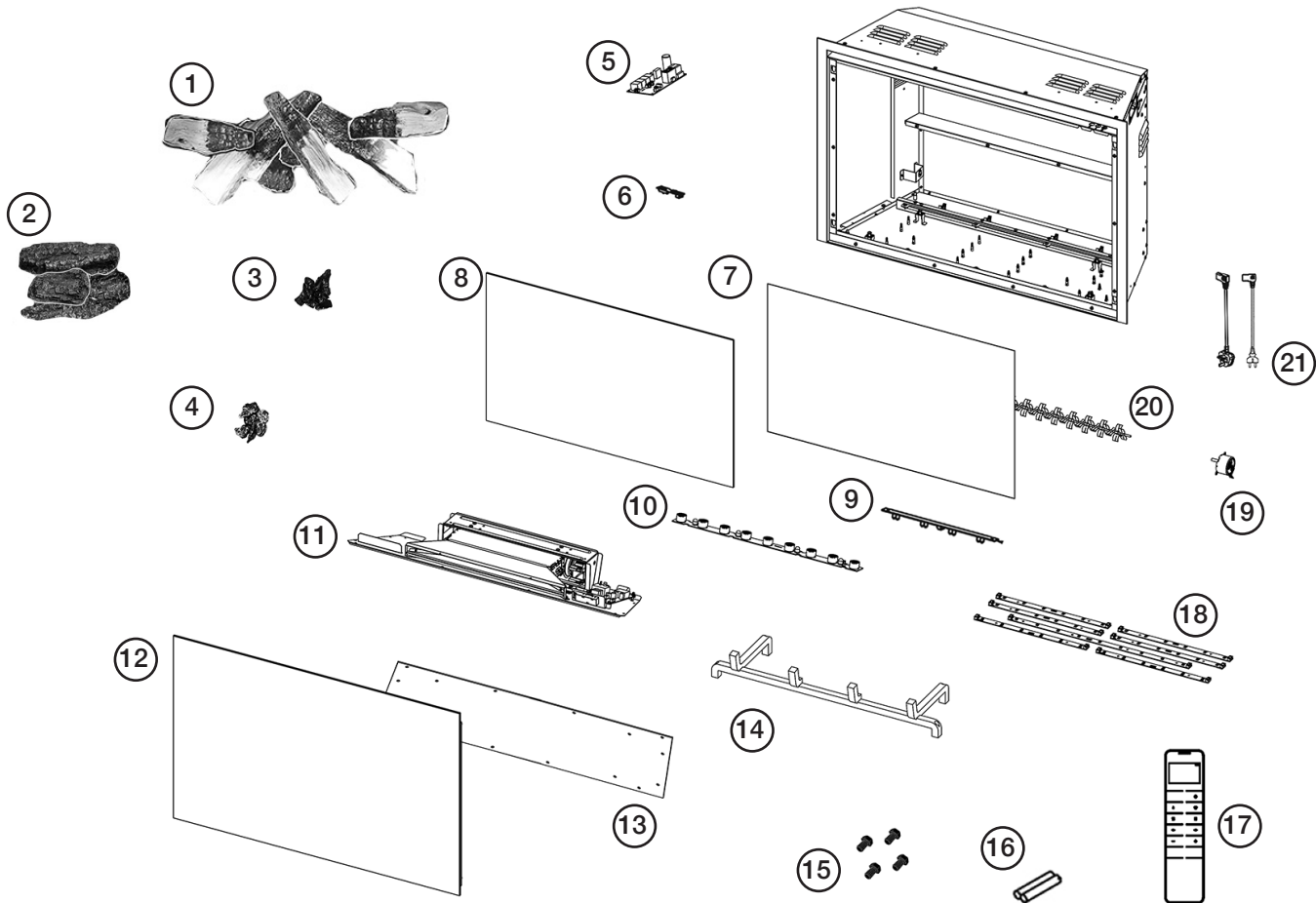

No.	eMotiv 64		eMotiv 74		eMotiv 84	
	Part Code	Qty	Part Code	Qty	Part Code	Qty
1	CE2222	1	CE2222	1	CE2238	1
2	CE2235	1	CE2224	1	CE2240	1
3	CE2303	1	CE2303	1	CE2303	1
4	CE2234	1	CE2223	1	CE2239	1
5	EL1154	1	EL1154	1	EL1154	1
6	EL1153	1	EL1153	1	EL1153	1
7	PL0276	1	PL0265	1	PL0280	1
8	CE2237	1	CE2226	1	CE2242	1
9	EL1155	1	EL1008	1	EL1162	1
10	EL1160	1	EL1161	1	EL0723	1
11	EL1157	1	EL1158	1	EL1159	1
12	CE2291	1	CE2292	1	CE2293	1

No.	eMotiv 64		eMotiv 74		eMotiv 84		
	Part Code	Qty	Part Code	Qty	Part Code	Qty	
13	PL0277	1	PL0266	1	PL0281	1	
14	PL0279	1	PL0268	1	PL0283	1	
15	FA0870	1	FA0870	1	FA0870	1	
16	EL0062	1	EL0062	1	EL0062	1	
17	EL1156	1	EL1156	1	EL1156	1	
18	RC07-288A	N/A	-	EL1060	8	EL1060	1
	RC07-289A	N/A	-	N/A	-	EL1111	7
	RC07-290A	EL1061	4	N/A	-	N/A	-
19	EL0632	1	EL0632	1	EL0632	1	
20	EL1109	1	EL1064	1	EL1113	1	
21	EL0714 -UK	1	EL0714 -UK	1	EL0714 -UK	1	
	EL0542 -EU		EL0542 -EU				

NO.	ENGLISH	FRANÇAIS	DEUTSCHE	NEDERLANDS	ITALIANO	NORSK
1	Log Set	Jeu De Bûches	Holz Scheit-Set	Blokken Geplaatst	Set Di Ceppi	Kubbesett
2	Ember Effect	Bûches De Charbon	Glutholz Scheite	Glazen Blokken	Ceppi Di Brace	Glasskubbene
3	Glass Embers	Braises De Verre	Glasglut	Glazen Sintels	Cocchi In Vetro	Glassglor
4	Amber Crystals	Cristaux Ambrés	Bernsteinfarbener Brennstoffeffekt	Roodachtige Kristallen	Cristalli Zenzero	Oransje Krystaller
5	PCB	Circuit Imprimé	Platine	P.C.B.	P.C.B.	Hovedkretskort
6	Receiver	Panneau Du Récepteur	Empfängerplatine	Ontvangstpaneel	Ricevitore	Mottager-Kort
7	Inner Screen	Écran Intérieur	Innenblende	Binnenscherm	Schermo Interno	Innerskjermen
8	Rear Glass	Vitre Arrière	Hintere Scheibe	Glas Achter	Vetro Posteriore	Bakglass
9	Downlight	Luminaire	Downlight	Down Light	Luce Verso Il Basso	Nedovervendt Lys
10	Flame Effect LED Board	Panneau à LED Des Effets De Flamme	Flammeneffekt-LED-Platine	Vlameffect LED-paneel	Pannello di LED Dell'effetto Fiamma	Flamme-effekt LED-kort
11	Heater Assembly	Ensemble Chauffage	Heizeinheit	Kachelassemblage	Gruppo Riscaldatore	Varmekomponent
12	Front Glass	Vitre Avant	Frontscheibe	Glas Voorkant	Vetro Frontale	Frontglass
13	Fuel Bed	Lit De Combustible	Brennstoffbett	Brandstofbed	Crogiolo Di Combustione	Brennkammer
14	Grate	Grille	Glutrost	Rooster	Grata	Rist
15	Leveling Bolts (Set)	Boulons De Mise À Niveau (Jeu)	Nivellierschrauben (Satz)	Egaliseringsbouten (Set)	Bulloni Di Livellamento (Set)	Nivelleringsbolter (Sett)
16	AAA Battery	AAA Batterie	AAA Batterie	AAA Batterij I	AAA Pila	AAA Batteri
17	Remote	Télécommande	Fernbedienung	Afstandsbediening	Telecomando	Fjernkontroll
18	Fuel Effect LED Board	Panneau à LED des effets du lit de combustible	Brennstoffeffekt-LED-Platine	Brandstofbed LED-paneel	Pannello di LED dell'effetto combustibile	Brenseffekt LED-kort
19	Flame Motor	Moteur De Flammes	Flammenmotor	Brandmotor	Motore Della Fiamma	Flammemotor
20	Flame Spindle	Axe Des Flammes	Flammenspindel	Vlammenas	Eccentrico Fiamma	Flammespindel
21	Power Cable	Câble D'alimentation	Stromkabel	Voedingskabel	Cavo Di Alimentazione	Strømkabel

NO.	ESPAÑA	ΕΛΛΗΝΙΚΑ	LATVIEŠU	LÉTZEBUGESCH	PORTUGUÊS
1	Conjunto De Leños	Ποικιλία Ξύλων	Pagaļu Komplekts	Holzstéckersaz	Conjunto De Troncos
2	Leños Encendidos	Διακοσμητικά Ξύλα	Pagales	Holzglous	Brasas
3	Brasas De Vidrio	Διακοσμητικά Καρβουνα	Stikla Ogles	Glasglous	Brasas Em Vidro
4	Cristales Anaranjados	Χαλκοκόκκινοι Κρύσταλλοι	Oranži Kristāli	Geltoni Kristalai	Cristais Laranjas
5	Tarjeta De Circuito Impreso	Κεντρική Πλακέτα (PCB)	P.C.B.	PCB	PCB
6	Tablero Receptor	Πλακέτα Του Δέκτη	Ontvangstpaneel	Empfängerplatinn	Placa Do Recetor
7	Pantalla Interna	Εσωτερικής Σητας	Iekšējā Aizsietņ	Banneschte Bildschirm	Ecrã Interior
8	Cristal Posterior	Πίσω Γυαλί	Aizmugurējais Stikls	Galinis Stiklas	Vidro Traseiro
9	Intensidad Lumínica	Καθετος Φωτισμος	Lokālā Gaisma	Plaffongsbelichtung	Luz Embutida
10	Tablero LED con efecto de llama	Πλακέτα LED του εφέ φλόγας	Vlameffect LED-paneel	LED-Plack mat Flamenefekt	Placa de LED do efeito chama
11	Grupo Calefactor	Διάταξη Θερμαντικού	Sildītāja Bloks	Šildytuvo Mazgas	Conjunto De Aquecimento
12	Cristal Frontal	Μπροστινό Γυαλί	Priekšējais Stikls	Priekinis Stiklas	Vidro Frontal
13	Base De Combustible	Κλίνη Καυσίμου	Degošais Slānis	Kuro Sluoksnis	Leito De Combustível
14	Parrilla	Σχάρα	Režģis	Grotelés	Grelha
15	Pernos Niveladores (Juego)	Μπουλόνια Εξισορρόπησης (Σετ)	Izlīdzināšanas Skrūves (Komplekts)	Išlyginamieji Varžtai (Rinkinys)	Parafusos De Nivelção (Conjunto)
16	AAA Bateria	AAA ΜΠΑΤΑΡΙΑ	AAA Baterija	AAA Batterie	AAA Bateria
17	Control Remoto	Τηλεχειριστήριο	Tālvadības Pults	Nuotolinis	Controlo Remoto
18	Tablero LED de efecto combustible	Πλακέτα LED του εφέ καυσίμου	Brandstofbed LED-paneel	Brennstoffeffekt-LED-Plack	Placa de LED do efeito combustível
19	Motor De Llamas	Μοτέρ Φλόγας	Liesmas Motors	Liepsnos Variklis	Motor De Chama
20	Varilla De Llama	Άτρακτος Φλόγας	Liesmas Vārpsta	Liepsnos Velenēlis	Fuso De Chama
21	Cable De Alimentación	Καλώδιο Τροφοδοσίας	Barošanas Kabelis	Maitinimo Kabelis	Cabo De Alimentação

GB: PRODUCT MATERIAL INFORMATION
FR: INFORMATIONS MATÉRIELLES DU PRODUIT
DE: PRODUKTMATERIALINFORMATIONEN
NL: PRODUCT MATERIAAL INFORMATIE

GB:

When the waste bin symbol with a cross is found on a product, it means that this product is subject to the European Directive 2012/19 / EU (implemented by the national legislation with the legislative decree of March 14, 2014, n.49).

In accordance with European Directive 2012/19/ EU, waste electrical and electronic equipment (WEEE) must not be disposed of with household or unsorted municipal waste.

At the end of its useful life please take this product to an appropriate recycling centre, collection point or utilise a distributor take-back service. Failure to do so may result in negative effects on the environment and/or human health as a result of the possible presence of hazardous substances in electrical and electronic equipment and of the mishandling of such equipment.

You can find your nearest recycling centre by contacting your local authority, for UK customers using the bank locator at www.recycle-more.co.uk or for customers in the Republic of Ireland at www.weeeireland.ie. Take-back services can be discussed with your authorised dealer.

-

FR:

Le symbole de poubelle avec une croix mentionné sur ce produit signifie que ce dernier est soumis à la directive européenne 2012/19/EU (mise en application par le décret législatif n° 49 du 14 mars 2014).

Conformément à la directive européenne 2012/19/EU, les déchets d'équipements électriques ou électroniques (DEEE) ne doivent pas être éliminés avec les déchets ménagers ou municipaux non triés.

À la fin de sa vie utile, veuillez déposer ce produit dans un centre de collecte ou de recyclage approprié, ou utiliser le service de reprise du distributeur. La non-exécution pourrait entraîner des effets néfastes sur l'environnement et/ou la santé humaine en raison de l'éventuelle présence de substances dangereuses dans les équipements électriques et électroniques et de la mauvaise utilisation d'un tel équipement.

Vous pouvez trouver le centre de recyclage le plus proche en contactant les autorités locales. Les clients au Royaume-Uni peuvent se servir du système de repérage sur www.recycle-more.co.uk et ceux de la République d'Irlande sur www.weeeireland.ie. Vous pouvez vous enquérir des services de reprise auprès de votre distributeur agréé.

-

DE:

Wenn das Symbol einer durchgestrichenen Mülltonne auf einem Produkt zu finden ist, bedeutet dies, dass dieses Produkt der europäischen Richtlinie 2012/19/EU unterliegt (umgesetzt in der nationalen Gesetzgebung mit dem Gesetzesdekret vom 14. März 2014, Nr. 49).

Gemäß der europäischen Richtlinie 2012/19/ EU dürfen Elektro- und Elektronik-Altgeräte (WEEE) nicht über den Hausmüll oder unsortierten Siedlungsabfall entsorgt werden.

Bitte geben Sie dieses Produkt am Ende seiner Nutzungsdauer bei einem geeigneten Recyclingzentrum oder einer Sammelstelle ab oder nutzen Sie den Rücknahmeservice eines Händlers. Andernfalls kann dies zu negativen Auswirkungen auf die Umwelt und/oder die menschliche Gesundheit führen, wenn möglicherweise gefährliche Stoffe in Elektro- und Elektronikgeräten vorhanden sind und diese Geräte falsch gehandhabt werden.

Für den nächstgelegenen Recyclinghof wenden Sie sich an Ihre Gemeindeverwaltung. Kunden in Großbritannien finden diesen über den Bank Locator unter www.recycle-more.co.uk, Kunden in der Republik Irland über www.weeeireland.ie. Rücknahmeleistungen können mit Ihrem Vertragshändler besprochen werden.

-

NL:

Een afvalbaksymbool met een kruis erdoorheen op een product betekent dat het betreffende product valt onder de Europese richtlijn 2012/19 / EU (in Groot-Brittannië verwerkt in de nationale wetgeving naar aanleiding van een rechterlijke uitspraak geregistreerd onder nr. 49 van 14 maart 2014).

In overeenstemming met de Europese richtlijn 2012/19 / EU mag defecte elektrische en elektronische apparatuur niet worden afgevoerd via het normale huisafval of grofvuil.

Breng dit product dan ook naar een geschikt recycling-centrum, inzamelpunt of maak gebruik van een terugname-service van een distributeur zodra dit versleten is. Doet u dit niet, dan kan dat negatieve gevolgen hebben voor de omgeving en/of de gezondheid vanwege de mogelijke aanwezigheid van gevaarlijke stoffen in elektrische en elektronische apparatuur en verkeerde verwerking van dergelijke apparatuur.

Neem contact op met uw gemeente voor informatie over de dichtstbijzijnde milieustraat; klanten in het Verenigd Koninkrijk kunnen ook kijken op www.recycle-more.co.uk en klanten in de Ierse Republiek op www.weeeireland.ie. Voor informatie over een terugname-service kunt u contact opnemen met uw erkende dealer.

IT: INFORMAZIONI SUL MATERIALE DEL PRODOTTO
NO: INFORMASJON OM PRODUKTMATERIALE
ES: INFORMACIÓN DEL MATERIAL DEL PRODUCTO

IT:

Quando su un prodotto compare il simbolo del cestino dei rifiuti con una croce, significa che il prodotto è soggetto alla Direttiva europea 2012/19/UE (recepita dalla legislazione nazionale con il decreto legislativo del 14 marzo 2014, n.49).

In conformità alla Direttiva europea 2012/19/UE, le apparecchiature elettriche ed elettroniche (RAEE) non devono essere smaltite insieme ai rifiuti domestici o ai rifiuti urbani indifferenziati.

Al termine della vita utile del prodotto, occorre portarlo presso un centro di riciclaggio o un punto di raccolta appropriato oppure utilizzare il servizio di ritiro offerto dal distributore. In caso contrario, potrebbero verificarsi effetti negativi sull'ambiente e/o sulla salute umana a seguito dell'eventuale presenza di sostanze pericolose nelle apparecchiature elettriche ed elettroniche e dell'errata gestione di tali apparecchiature. Per conoscere il centro di riciclaggio più vicino contattare le autorità locali. I clienti del Regno Unito possono utilizzare il localizzatore presente sul sito www.recycle-more.co.uk mentre i clienti della Repubblica d'Irlanda possono consultare il sito www.weeeireland.ie. Per maggiori informazioni sui servizi di ritiro rivolgersi al proprio rivenditore autorizzato.

-

NO:

Når søppelkassesymbolet med et kryss står på et produkt, betyr det at dette produktet er underlagt det europeiske direktivet 2012/19/EU (implementert av nasjonal lovgivning med lovdekret av 14. mars 2014, n. 49).

I henhold til det europeiske direktivet 2012/19/EU, må ikke avfall fra elektrisk og elektronisk utstyr (WEEE) kastes sammen med husholdningsavfall eller usortert kommunalt avfall.

Ved slutten av levetiden, ta dette produktet til en egnet gjenvinningsstasjon, innsamlingspunkt eller bruk returtjenesten til en distributør.

Unnlattelse av å gjøre dette kan føre til negative konsekvenser for miljøet og/eller menneskers helse som følge av potensielt farlige stoffer i elektrisk og elektronisk utstyr, og feil håndtering av slikt utstyr.

Du kan finne din nærmeste gjenvinningsstasjon ved å kontakte lokale myndigheter. Kunder i Storbritannia finner informasjon om dette på www.recycle-more.co.uk, mens kunder i Irland kan gå til www.weeeireland.ie. Tilbakeleveringstjenester kan diskuteres med din autoriserte forhandler.

-

ES:

Si un producto cuenta con el símbolo del contenedor de residuos con una cruz, estará sujeto a la Directiva Europea 2012/19/UE (implementada a través de la legislación nacional con el decreto legislativo de 14 de marzo de 2014, número 49).

De acuerdo con la Directiva Europea 2012/19/UE, los residuos de dispositivos eléctricos y electrónicos (WEEE) no se deben desechar a través de los sistemas de eliminación de residuos domésticos ni residuos urbanos sin clasificar.

Al finalizar su vida útil, lleve el producto al centro de reciclaje correspondiente o al punto de recogida, o use un servicio de recogida de los distribuidores. De lo contrario, se pueden producir efectos negativos en el medio ambiente y/o en la salud humana derivados de la posible presencia de sustancias perjudiciales en los dispositivos electrónicos o eléctricos, y a la manipulación incorrecta de estos.

Para encontrar su centro de reciclaje más cercano, póngase en contacto con las autoridades locales. Alternativamente, los clientes en el Reino Unido pueden usar el buscador www.recycle-more.co.uk y los clientes en la República de Irlanda pueden usar la dirección www.weeeireland.ie. Los servicios de recogida se pueden analizar con su distribuidor autorizado.

GR: ΠΛΗΡΟΦΟΡΙΕΣ ΥΛΙΚΟΥ ΠΡΟΪΟΝΤΟΣ
LV: INFORMĀCIJA PAR PRODUKTU MATERIĀLIEM
LU: PRODUIT MATERIAL INFORMATIUNEN
PT: INFORMAÇÕES SOBRE O MATERIAL DO PRODUTO

GR :

Όταν ένα προϊόν συνοδεύεται από το σύμβολο του τροχήλατου κάδου απορριμμάτων που διαγράφεται με ένα σταυρό, αυτό σημαίνει ότι το προϊόν υπόκειται στην Ευρωπαϊκή Οδηγία 2012/19/ΕΕ (η οποία ενσωματώθηκε στην εθνική νομοθεσία με την ΚΥΑ 23615/651/Ε.103 (ΦΕΚ Β 1184/9.5.2014)).

Σύμφωνα με την Ευρωπαϊκή Οδηγία 2012/19/ ΕΕ, τα απόβλητα ηλεκτρικού και ηλεκτρονικού εξοπλισμού (ΑΗΗΕ) δεν επιτρέπεται να απορρίπτονται μαζί με τα οικιακά ή τα μη ταξινομημένα αστικά απορρίμματα.

Όταν αυτό το προϊόν βρίσκεται στο τέλος της ωφέλιμης ζωής του, παρακαλούμε να το μεταφέρετε σε κατάλληλο κέντρο ανακύκλωσης ή σημείο συλλογής ή να χρησιμοποιήσετε μια υπηρεσία ανακύκλωσης του διανομέα. Η μη τήρηση των παραπάνω μπορεί να οδηγήσει σε αρνητικές επιπτώσεις στο περιβάλλον ή/και στην ανθρώπινη υγεία λόγω της πιθανής παρουσίας επικίνδυνων ουσιών στον ηλεκτρικό και ηλεκτρονικό εξοπλισμό ή λόγω του κακού χειρισμού αυτού του εξοπλισμού.

Μπορείτε να βρείτε το πλησιέστερο κέντρο ανακύκλωσης επικοινωνώντας με την τοπική σας αρχή, οι πελάτες στο Ηνωμένο Βασίλειο χρησιμοποιώντας τον εντοπισμό σημείου ανακύκλωσης στη διεύθυνση www.recycle-more.co.uk και οι πελάτες στη Δημοκρατία της Ιρλανδίας στη διεύθυνση www.weeireland.ie. Οι υπηρεσίες ανακύκλωσης μπορούν να συζητηθούν με τον εξουσιοδοτημένο αντιπρόσωπό σας.

-

LV :

Ja uz produkta ir atrodams atkritumu tvertnes simbols ar krustiņu, tas nozīmē, ka uz šo produktu attiecas Eiropas direktīva 2012/19 / ES (īstenošana ar valsts tiesību aktiem ar 2014. gada 14. marta likumdošanas dekrētu Nr. 49).

Saskaņā ar Eiropas Direktīvu Nr. 2012/19/ ES elektrisko un elektronisko iekārtu (EElA) atkritumus nedrīkst izmest kopā ar sadzīves vai nešķirotiem sadzīves atkritumiem.

Pēc ierīces darbības beigām šis produkts jānogādā atbilstošā pārstrādes centrā, savākšanas punktā vai jāizmanto izplatītāja izmantošanas pakalpojumi. Pretējā gadījumā iespējamās bīstamo vielu klātbūtnes dēļ elektriskās un elektroniskās iekārtās un, nepareizi rīkojoties ar šādām iekārtām, ir iespējama negatīva ietekme uz vidi un/vai cilvēku veselību.

Tuvāko pārstrādes centru var atrast, sazinoties ar savu pašvaldību, patērētāji AK reciklēšanas centrus var atrast vietnē www.recycle-more.co.uk, savukārt patērētāji Īrijas Republikā reciklēšanas centrus var atrast vietnē www.weeireland.ie. Utilizēšanas pakalpojumus var apspriest ar pilnvaroto preču izplatītāju.

-

LU :

Wa sech kee Dreckskëschtssymbol mat engem Kräiz op engem Produkt befënnt, bedeit dat, datt dëst Produkt der Europäescher Richtlinn 2012/19/EU ënnerläit (ëmgesat duerch national Gesetzgebung mat der Gesetzesveruerdung vum 14. März 2014, Nr. 49).

Geméiss der EU-Richtlinn 2012/19/EU däerfen Elektro- an Elektronikapparater (WEEE) net am Haushaltsoffall oder onsortéiertem Hausoffall entsuergt ginn.

Bréngt dëst Produkt um Enn vu senger Nutzungsdauer zu engem gëeegente Recyclagezenter, enger Sammelplaz oder engem Recuperatiounsservice vun engem Händler. Eng Netbeuechtung kann et opgrond vun der méiglecher Uwiesenheet vu geféierlech Stoffen an Elektro- an Elektronikapparater an der onsaachgeméisser Handhabung vun esou Apparater zu negativen Auswierkungen op d'Ëmwelt an/oder d'mënschlech Gesondheet kommen.

Dir kënn Ären nächste Recyclagezenter fannen, andeem Dir Iech un Är lokal Autoritéite went. Fir Clienten aus Groussbritannien iwwer d'Onlinesäit www.recycle-more.co.uk oder fir Clienten aus der Republik Irland ënner www.weeireland.ie. Recuperatiounsservicer kënnen mat Ärem Vertragshändler beschwat ginn.

-

PT :

Quando se encontra num produto o símbolo do caixote do lixo com uma cruz, significa que este produto está sujeito à Diretiva Europeia 2012/19/UE (implementada pela legislação nacional com o decreto legislativo de 14 de março de 2014, n.49).

Em conformidade com a Diretiva Europeia 2012/19/UE, os resíduos de equipamentos elétricos e eletrónicos (REEE) não devem ser eliminados juntamente com resíduos domésticos ou resíduos urbanos não separados.

No fim da sua vida útil, deixar este produto num centro de reciclagem ou ponto de recolha apropriado ou utilizar um serviço de retoma do distribuidor. O não cumprimento desta recomendação pode causar efeitos negativos no ambiente e/ou na saúde humana como resultado da possível presença de substâncias perigosas em equipamentos elétricos e eletrónicos e da má utilização desses equipamentos.

Pode encontrar o centro de reciclagem mais próximo contactando as autoridades locais, para clientes no Reino Unido utilizando o localizador de aterros em www.recycle-more.co.uk ou para cliente na República da Irlanda em www.weeireland.ie. Os serviços de retoma podem ser discutidos com o seu distribuidor autorizado.

FOR ENQUIRIES IN THE U.K (EXCLUDING NI):

**Stovax Gazco Limited, Spitfire Avenue, Skypark, Clyst Honiton, Exeter, Devon, England
EX5 2FR**

Tel: (01392) 261900 E-mail: info@gazco.com

FOR ENQUIRIES IN EUROPE (INCLUDING NI):

**Stovax Heating Group (NI) Ltd (Comp reg NI675194), 40 Linenhall Street, Belfast, BT2
8BA DX 400 NR Belfast Tel: +44 (0)1392 261990 E-mail: northernireland@gazco.com**

